

**EVALUATING
ACADEMIC READINESS
FOR APPRENTICESHIP TRAINING**
Revised for
ACCESS TO APPRENTICESHIP

**SCIENCE SKILLS
BASIC ELECTRICAL CIRCUITS**

**AN ACADEMIC SKILLS MANUAL
for**

The Construction Trades: Structures

This trade group includes the following trades:
Drywall & Acoustical Applicator, General Carpenter,
Mason (Brick & Stone and Restoration), Reinforcing Rod Worker, Roofer,
Terrazzo, Tile & Marble Mechanic

*Workplace Support Services Branch
Ontario Ministry of Training, Colleges and Universities*

Revised 2011

In preparing these Academic Skills Manuals we have used passages, diagrams and questions similar to those an apprentice might find in a text, guide or trade manual.

This trade related material is not intended to instruct you in your trade. It is used only to demonstrate how understanding an academic skill will help you find and use the information you need.

SCIENCE SKILLS

BASIC ELECTRICAL CIRCUITS

*An academic skill required for the study of the
Construction Trades: Structures*

INTRODUCTION

Although an electrician does the wiring on most construction sites, the construction workers are the ones who build the structures that the wires run through. Understanding the basic principles of how electricity works will let you confidently discuss with the electrician how and where he plans to proceed.

Working around electrical circuits can be dangerous. If you are doing a renovation, you have to work near live wires. On the job site, you have to be sure your power tools are properly grounded with approved plugs. When operating a hoist, you have to be aware of overhead wires. A basic knowledge of electricity can help you work safely around electrical wires.

This skills manual looks at the basic principles of an electrical circuit. It examines the following topics:

- ◆ Electrostatic charge
- ◆ Creating an electrical current
- ◆ Conductors and insulators
- ◆ Grounding an object
- ◆ A simple direct current circuit
- ◆ Ohm`s Law
- ◆ Circuit diagrams
- ◆ Circuits connected in series
- ◆ Circuits connected in parallel

ELECTROSTATIC CHARGE

During a thunderstorm, flashes of lightning brighten the sky. Lightning is a dramatic example of the reaction that can occur between objects that develop ***opposite electrical charges***. The charges that build up between the earth and clouds, resulting in the discharge of lightning, are the same kind of charges that can be used to generate an electric current. Both phenomena occur because objects can become electrically charged. Charged objects are said to have an ***electrostatic charge***.

All matter is composed of atoms, which in turn are composed of subatomic particles. Two of these particles, protons and electrons, possess a property called **charge**. The charge on an electron is different from the charge on a proton. This is similar to the difference between the two poles of a magnet. Like the opposite poles of a magnet, the two different charges are attracted to each other. While the different charges on electrons and protons cause them to be attracted to each other, particles with the same kind of charge are repelled by each other.

The charge on a proton is called a **positive charge**. A positive charge is indicated by a plus sign (+). The charge on an electron is called a **negative charge**. A negative charge is indicated by a minus sign (-).

An electron and a proton have opposite charges and, therefore, are attracted to each other.

- This attraction is felt as a pull towards each other.
- If the particles are free to move, the force of attraction causes them to move towards each other.
- During a thunderstorm, the earth and the clouds have opposite charges.
 - The negatively charged electrons in the clouds are attracted to the positively charged areas of the earth.
 - The negative electrons flow towards the positively charged areas as lightning strikes.

Two electrons repel each other because they are both negative. Two protons repel each other because they are both positive.

- The repulsion between two electrons or two protons is felt as a push away from each other.
- If the two electrons or two protons are free to move, this force causes the two particles to move away from each other.
- In an electrical wire, there are large numbers of electrons moving along the outside of the metal.
 - The electrons flow to move away from each other.
 - The energy of the moving electrons can be used to do electrical work.

The reaction of electrons and protons to their different charges can be summed up by saying:

- ◆ **opposite charges attract**
- ◆ **like charges repel**

If an atom has the same number of protons and electrons, the charges balance each other. The atom is neutral; it has no charge. An atom is only considered to have a charge if there are more electrons than protons or more protons than electrons.

How do atoms, and larger objects, become charged? The answer is found in the way electrons and protons behave. Protons are found inside the nucleus of the atom and are not free to move. Electrons are found on the outside of the atom and they can move from one atom to another atom. If an electron moves from one atom to another, then the atom that gains an electron becomes negatively charge and the atom that loses an electron becomes positively charge.

Since protons are securely held in the nucleus by strong nuclear forces and only electrons are free to move, charges on objects can only come from a **deficiency** (not enough) or an **excess** (more than enough) of **electrons**.

In the same way that an atom can become charged, a larger object can become charged. This happens if a large number of the atoms that make it up become charged. Since electrons are negatively charged, gaining electrons will give an object a negative charge, while losing electrons will give the object a positive charge.

In brief:

- ◆ An excess of electrons compared to the number of protons gives a **negative** charge.
- ◆ A deficiency of electrons compared to the number of protons gives a **positive** charge.

CREATING AN ELECTRIC CURRENT

Negative and positive charges can be created on separate metal plates. When there is a build up of electrons on a plate, the plate will have a negative charge. When electrons are removed from a plate, the plate will have a positive charge.

It takes energy to create a charged plate. Work must be done to move similarly charged particles closer together against the force of repulsion. At a later time, the work done to create the charged plates can be used to do electrical work. The energy needed to charge the plates can come from a mechanical source such as generators in a hydro dam, chemical reactions in a battery, solar panels that trap the sun's energy or thermal sources such as coal-burning generator stations.

A dry cell is made when two differently charged plates are connected by a wire. The excess electrons from the negative plate can flow to the positive plate. The flowing electrons create an electrical current. An **electric current** consists of charged electrons moving through a conductor.

In order for a current to flow between two plates, the connecting wire must allow electrons to move through it freely. It must be a good conductor. See Figure 1.

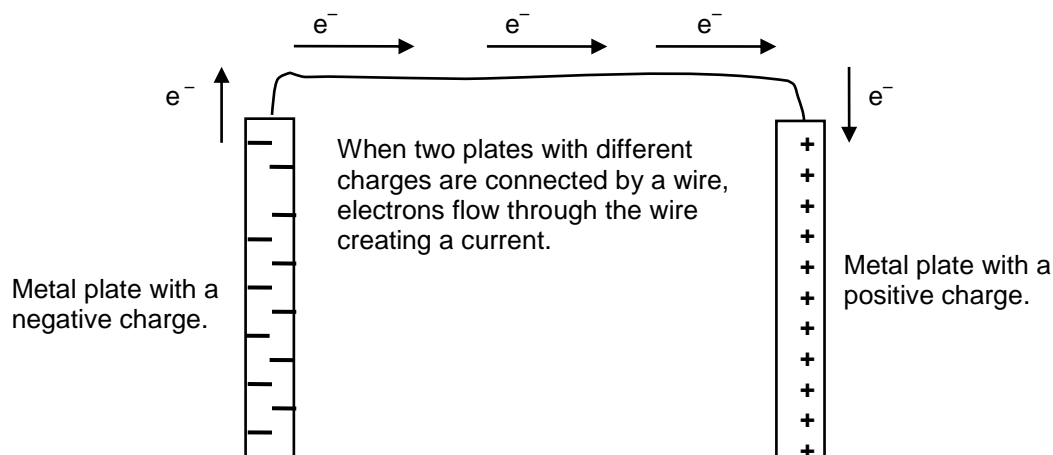
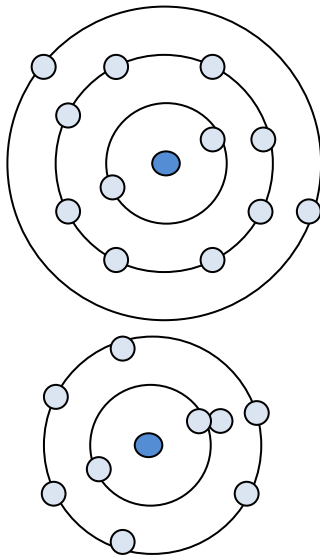

FIGURE 1: Creating An Electric Current

The amount of electrical work the electrical current can do when the electrons are free to move is measured as voltage. **Voltage** is a measure of the ability to produce electrical energy. The energy is stored, ready to do electrical work like lighting a bulb or running a drill.

CONDUCTORS AND INSULATORS

A **conductor** is any material that allows the free movement of electrons from one atom to another. Whether a material makes a good conductor or not depends on its atomic structure. Materials made from metal atoms that have few electrons in their outer shell make good conductors. Materials with an almost filled outer shell tend to make good insulators.



Conductor – Aluminum atom has only a few electrons in the outer shell which it easily gives up.

Insulator – Oxygen atom has an outer shell that is almost filled. The atom will accept electrons but won't give them up.

FIGURE 2: Atomic Structure Determines If A Material Is A Conductor Or An Insulator

Metal elements like copper and aluminum have *only a few electrons in their outer shell*. These electrons are easily dislodged. The atoms in a metal wire share these outer electrons as a cloud of electrons that move from atom to atom. The metals used to conduct electricity allow electrons to flow easily along their length.

Silver is a very good metal conductor, but it is only used commercially in special circuits because it is expensive. Copper is also an excellent conductor. Most electrical circuits use copper wire as the conductor as copper is plentiful and not too expensive.

An **insulator** is a material which does not readily transfer an electric charge. As important as conductors are for the transmission of electricity, insulators are also needed so that electricity can be conducted safely.

When electrical conductors are connected to supporting structures, insulators prevent the current from flowing where it is not wanted. Glass, ceramics, hard rubber, dry air and many plastics make good insulators. Materials that make good insulators are made of atoms that have *almost filled outer shells*. These atoms hold their electrons very tightly and will even take electrons from

other atoms. Unlike metals, they do not let their outer electrons flow to other atoms.

An electrical current will flow anywhere it finds a conductor. If metal wire used to hoist materials contacts electrical wires, electricity will flow into the hoisting wire and any person touching the wires or the hoist. An electrical current can cause a dangerous shock and even death if it flows through a person, so care must be taken when lifting materials near electrical wires.

GROUNDING AN OBJECT

A good conductor does not resist the free movement of electrons. Since like charges repel, the free-moving, negatively charged electrons will spread evenly throughout a conductor to get away from each other as much as possible. In this way they distribute the charges equally over the material. If there is a source of positive charge, they will move in that direction.

The earth is considered a limitless source of electrons and also an immense sink into which electrons can be poured. The earth is so large that countless electrons can pass into or out of it without changing its charge or its potential to store electrical energy. It is too big to respond to any change. Since the charge on an object spreads out evenly throughout that object, any charge on a part of the earth gets spread out and is lost as it disappears into the huge volume of the earth.

The amount of charge on the earth is considered to be zero. Any conducting object connected to the earth will reach an equilibrium with the earth. All its charge will empty into the earth. *An object connected to the earth is said to be **grounded**.* The main current entering a building is grounded by a neutral wire which protects against contact with a dangerous voltage when electrical insulation fails. In larger structures, the grounding wire is connected to the structural steel used in the building.

***Note:** Lightning is an exception to this rule. An area of the earth can have some electrons move away as a result of the repulsion from a negative charge in the clouds. This local area now has a positive charge. The positive area then attracts the electrons in the clouds, resulting in an arc of electrons that is called lightning.*

A SIMPLE DIRECT CURRENT CIRCUIT

Electrons that have moved close together have more potential energy than normally spaced ones. This potential difference is called voltage and is measured in **volts**. It is like a pressure or force, sitting there ready to do electrical work. For this reason, voltage is also called **electromotive force** or **emf**. In the formula which describes a circuit (Ohm's law), voltage is abbreviated as either V or E.

Because the earth is a limitless source of electrons and also a limitless sink into which electrons can be emptied, the potential of the earth to be charged is considered to be zero. All measurements of potential difference at any points in an electrical field, either negative or positive, are taken against the earth as reference point zero. So a 12 volt battery has a potential difference of 12 volts compared to the earth at 0 volts.

Work Done by Moving Electrons

If two plates with different charges are connected to each other by a wire, electrons will flow from the negative plate, which has excess electrons, to the positive plate, which is deficient in electrons. This flow of electrons creates a current.

*A **current** (I) is the rate of flow of electrons through a conductor past a certain point in the circuit. It is measured in **amperes** (a).*

If a load, such as a light bulb, is connected to the wire, moving electrons are able to use their electrical potential energy to do work on the load. Electrical energy is changed into light and heat, resulting in the bulb producing light used to brighten dark areas. The moving electrons in the wire carry electrical energy that can be used to do many kinds of work, from producing heat to running the motors in power tools. Moving electrons form the basis of an electrical circuit.

The kind of basic circuit just described produces a **direct current** (dc). The current flows in one direction. This is the kind of current used in batteries. To move the vast amount of current needed in commercial and residential systems, it was found that current could be moved more efficiently if the electrons alternated direction back and forth in the wires. This kind of current is called **alternating current** (ac).

Alternating current is used to provide electricity to buildings in much of the world. It is the kind of current you will be working around. However, it is easier to show the relationships between voltage, current and load using a simple, direct circuit. The basic principles also apply to an alternating current.

Resistance in a Circuit

An electric circuit includes a source of voltage, a conducting wire and a device or load that uses the current to do work. The load creates an opposition to the flow of electrons in the circuit. Even wires that are good conductors provide some opposition to the flow of electricity. *This opposition to the flow of electricity is called **resistance** (R). The load or resistance is measured in **ohms** (Ω).*

OHM'S LAW

In a direct current cell, there is a close relationship between voltage, current and resistance. A scientist named Georg Ohm studied electric circuits and found that the value of the resistance of a circuit is equal to the voltage divided by the amount of current. This ratio is called **Ohm's law**. Ohm's law states: *The resistance of the circuit is equal to the ratio of the voltage to the current.*

In the formula expressing this relationship:

- ◆ R = resistance, expressed in ohms (Ω)
- ◆ V = voltage, expressed in volts (v)
- ◆ I = current, expressed in amperes (a)

The formula for Ohm's Law is: $\text{resistance} = \frac{\text{voltage}}{\text{current}}$

$$R = \frac{V}{I}$$

To find the voltage in a direct current cell: $\text{voltage} = \text{current} \times \text{resistance}$

$$V = IR$$

To find the current in a direct current cell: $\text{current} = \frac{\text{voltage}}{\text{resistance}}$

$$I = \frac{V}{R}$$

If you know two quantities in the formula, you can find the third. If you are given the voltage and the resistance of the circuit, you can find the current.

Example: If the voltage is 12 volts and the total resistance is 24 ohms, what is the current?

Use the formula that shows "I" on the left.

$$I = V/R$$

$$I = 12\text{v} / 24 \Omega$$

$$I = .5 \text{ a}$$

Example: If the current is 6 amperes and the voltage is 60 volts, what is the resistance on the circuit?

$$R = V/I$$

$$R = 60\text{v} / 6\text{a}$$

$$R = 10 \Omega$$

Example: If the current is 10 amperes and the total resistance is 12 ohms, what is the voltage?

$$V = IR$$

$$V = 10\text{a} \times 12 \Omega$$

$$V = 120\text{v}$$

If you change either resistance, voltage or current, at least one of the other quantities also changes. If you put a battery of lower voltage in a circuit and the resistance remains the same, the current will decrease. If two circuits have the same voltage, but one has more resistance, the current will be less in the circuit with more resistance.

Ohm's law explains the following relationships in a circuit:

- ◆ Increasing voltage results in increased current if resistance stays the same.
- ◆ Decreasing voltage results in a decrease in current if resistance stays the same.
- ◆ Increasing resistance decreases current if the voltage stays the same.
- ◆ Decreasing resistance increases current if the voltage stays the same.

The parts making up a direct circuit can be connected in more complex ways. For example, there can be two sources of voltage in the circuit or there can be several resistances. The relationship between voltage, current and resistance changes when circuits are connected in more complex ways. There are laws that describe these relationships. Before looking at these laws, we will look at basic circuit diagrams and how circuits can be connected. Circuit diagrams can help explain how more complex circuits are wired.

CIRCUIT DIAGRAMS

Conventional symbols such as those shown below and in the diagrams that follow are used to represent the components in circuit diagrams. These symbols are used to make diagrams of direct electrical circuits. Remember, the electric power supplied to buildings is not a direct current but an alternating current. In your work, you will learn to read blueprints that contain complicated diagrams of electrical wiring. But in order to explain the basic principles, we will look at simple examples of circuit diagrams.

Here are a few of the symbols used in circuit diagrams:

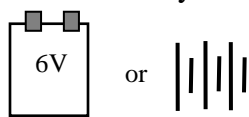

Cell or battery



Resistor (or load)



Ammeter

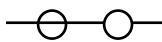

Switch (closed)



Switch (opened)

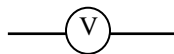

Voltmeter

Electrical symbols can be used to make diagrams of simple electrical circuits. The diagrams are helpful in understanding different problems concerning circuits. Figure 3 is an example of a circuit diagram.

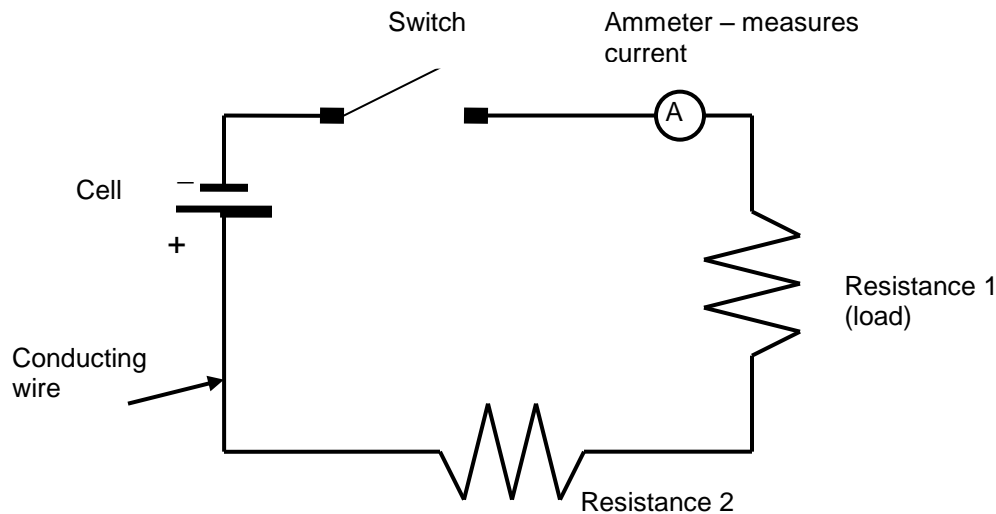

FIGURE 3: A Simple Direct Circuit

This circuit has a source of voltage, a conducting wire, a switch, two resistors and a device to measure current (an ammeter).

CIRCUITS CONNECTED IN SERIES

Earlier we described the source of voltage in a circuit as a charged plate. A charged plate is usually called a cell. A cell creates a certain amount of energy, depending on its voltage, that moves a certain amount of current around the circuit. Appliances that run on electrical current need to have the right amount of voltage to work properly. A flashlight that runs on 1.5 volts would burn out if connected to a 6 volt battery, while a car wouldn't get enough current to start on only 1.5 volts.

If one cell can't provide an adequate amount of voltage or current, cells can be combined to provide the amount required. Two or more cells connected together are called a **battery**. Cells can be combined in series, in parallel, or a series-parallel combination.

Cells connected in series

When cells are combined in series, the negative terminal of each cell is connected to the positive terminal of the next cell. The negative terminal of the last cell in the series is connected to the circuit wire, which completes the circuit by connecting back to the positive terminal of the first cell.

Each cell adds to the amount of potential electrical energy or voltage, because each cell pumps up the energy level. *The voltage in a circuit with cells connected in series is the combined voltage of each cell added together.* When cells are connected in series, the circuit will have a higher voltage than if there was just one cell.

The current in a circuit that is not divided into parallel branches is the same everywhere, because the identical current is flowing everywhere at the same rate. Because cells connected in series are one continuous circuit, the same amount of current must flow through each cell.

Resistances in series

Just as cells can be connected in series or in parallel, so can resistances. *If resistances are connected in series, the total resistance of the circuit is equal to the sum of all the different resistances.*

Figure 4 shows a circuit where both the cells and the resistances are connected in series.

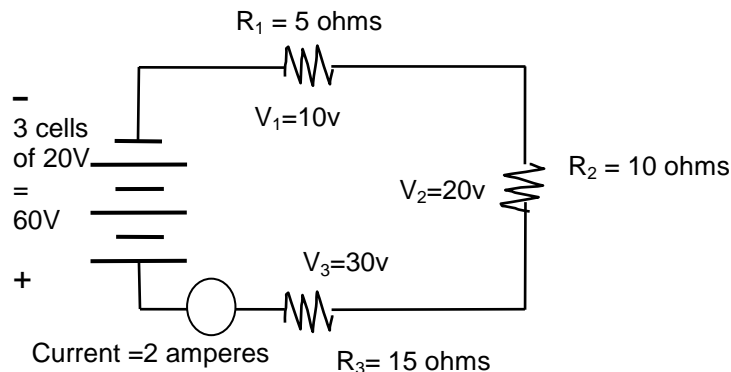

FIGURE 4: Electrical Circuit With Both Cells And Resistances Connected In Series

As the current moves through each resistance, some of the available voltage is used up. The resistances should use up all the energy in a circuit. The amount of energy used in the circuit is called the **voltage drop**. The voltage drop is the difference in voltage between two points.

Note : If the circuit is not connected (the switch is open), there is no voltage drop because no current is flowing.

If a battery provides 12 volts to the circuit, the resistances should use up all 12 volts before the current reaches the positive terminal of the battery. If there is one resistance, it should use about 12 volts of energy. If there are several resistances connected in series, each resistance will use less than 12 volts but the total voltage drop should equal 12 volts.

This brings us to **Kirchhoff's Voltage Law**, which states the relationship between the voltage drops and the applied voltage in a series circuit:

The sum of all the individual voltage drops is equal to the total voltage drop. The voltage drop across the circuit is equal to the applied voltage of the battery.

If there are three resistances in series, this can be expressed as the equation:

$$V_t = V_1 + V_2 + V_3$$

In this formula:

- ◆ V_t is the total applied voltage,
- ◆ V_1 is the first voltage drop,
- ◆ V_2 is the second voltage drop, and
- ◆ V_3 is the third voltage drop.

We can also say that the difference between the applied voltage and the sum of the voltage drops equals zero. In Figure 4, the applied voltage V_t is 60 v, the first voltage drop is 10 v, the second voltage drop is 20 v and the third voltage drop is 30 v. The equation can be rearranged to the following form to show that all the energy has been used by the circuit:

$$V_t - V_1 - V_2 - V_3 = 0$$

$$60\text{v} - 10\text{v} - 20\text{v} - 30\text{v} = 0$$

In Brief

- The voltage of the circuit is equal to the sum of the voltage of each cell;
- The current flowing in the cells and in the external circuit (wire, resistors) is the same everywhere in the circuit;
- The total resistance is equal to the sum of the individual resistances;
- The sum of the individual voltage drops across each resistor is equal to the total voltage drop;
- The total voltage drop across the circuit is equal to the voltage of the battery.

So, in Figure 4:

1. Three cells, each with 20 volts, are connected to make a 60 volt battery.
($20\text{v} + 20\text{v} + 20\text{v} = 60\text{v}$)
2. Three resistors are connected in series, equaling a total of 30 Ω .
($5 + 10 + 15 = 30 \Omega$)
3. The voltage of the battery is 60 volts, so the total voltage drop across the circuit is 60v.
4. Current is equal to voltage, 60v, divided by resistance, 30 ohms, which equals 2 amperes.
($60\text{v} \div 30 \Omega = 2\text{a}$)

CIRCUITS CONNECTED IN PARALLEL

Cells in Parallel

Circuits connected *in parallel* have all the negative terminals of each cell connected together by a wire. The last negative terminal is connected by the wire to the positive terminal of the first cell, which is then connected to the positive terminals of each of the other cells. See Figure 5.

The negative surface area of each cell is connected together, as is the positive surface area of each cell. This is like having one cell with a much larger surface area. Each cell connected in parallel should be at the same voltage, just as if they were one large cell. Having a larger cell doesn't create more voltage (electromotive force) because the *proportion of opposite charges remains the same*.

However, when cells are connected in parallel, more current is created because the bigger total surface area of the negative plate holds more electrons. The amount of current (the number of electrons flowing) contributed by each cell is added together to get the total current in the circuit.

The total current of the cell is equal to the sum of the individual currents contributed by each cell.

Making the surface area bigger only increases the total amount of current. It doesn't increase the amount of potential difference, so the voltage doesn't increase. Each cell in a parallel circuit must be at the same voltage, just as if it were one large cell. See Figure 5.

In a circuit connected in parallel:

- ◆ The voltage of the circuit is the same as the voltage of each individual cell, which must all have the same voltage.
- ◆ Since each cell has the same voltage, each cell supplies the same amount of current to the total amount. If there are three cells and the combined current is .75 amperes, each cell contributes .25 amperes to the total current.
- ◆ The total current of the circuit is the sum of the individual currents provided by each cell.

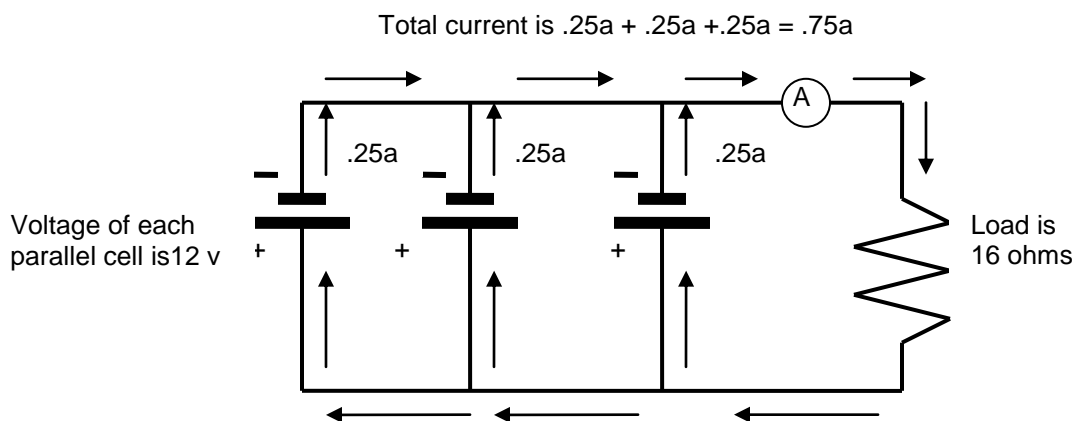

FIGURE 5: Cells Connected in Parallel

In the diagram:

- Each cell has a voltage of 12v, so the voltage of the circuit is 12v.
- Each cell provides .25a, so the current of the circuit is .75a.
- $(.25a + .25a + .25a = .75a)$
- Resistance is equal to voltage, 12v, divided by current, .75a, which is equal to 16 Ω
- $(12v \div .75a = 16 \Omega)$

CONCLUSION

Electrons and protons possess the property of charge that exerts a force on other charged particles. Electrons have a negative charge and protons have a positive one. Particles or objects with the same charge repel each other. Objects with the opposite charge attract each other.

When negatively charged electrons are moved against this electrical force of attraction or repulsion, work must be done on them by energy supplied from outside the electric field. The moved electrons now have stored electrical potential energy. When many electrons with electrical potential energy are connected by a wire to an area of positive charge or less negative charge, they will flow along the wire to the area of less charge.

The basic principles of electrical energy can be explained by looking at how a simple electrical circuit works. There is a close relationship between the voltage, current and resistance as described by Ohm's Law in a basic electrical circuit. Circuits can be arranged in series, in parallel or in complex combinations of both arrangements. These circuits provide electricity in a direct current. Electricity used in buildings is supplied in a more complex form called alternating current.

Answer the following questions by writing the correct words in the blank spaces. The answers are on the last page.

1. Two or more cells connected together are called a _____ .
2. In a battery, the electrons flow from the _____ terminal to the positive terminal.
3. The potential difference created by the charged plates, or the voltage or the emf, is measured in _____. The symbol is _____ .
4. The rate of flow of electrons along the wire is called _____ .
5. The unit of current is the _____. The short form or symbol is _____.
6. An appliance in a circuit that uses electrical energy to run is called a _____ or a load.
7. The unit for measuring resistance is the _____ and the symbol is _____
8. Label the following circuit symbols:

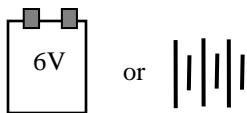







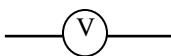

9. A circuit connected in series has three cells of 40 v each. The total voltage of the circuit is _____ v.
10. A circuit connected in series has three resistors of 10 Ω , 25 Ω , and 40 Ω . The value of the total resistance of the circuit is _____ Ω .
11. In cells connected in series, the current is the _____ everywhere in the circuit.

-
12. In cells connected in parallel, each individual cell must be at the same _____ as all the other cells.
 13. In cells connected in parallel, the total current of the circuit is equal to the _____ of the individual currents provided by each cell.
 14. Ohm's law states that the ratio of the voltage to the current is equal to the _____ of the circuit.
 15. Write the rest of the formula: $V = \underline{\quad} \underline{\quad}$
 16. If you put a battery of lower voltage in a circuit and the resistance stays the same, the current will _____ .
 17. If you increase the resistance and the voltage stays the same, the current will _____
 18. If a circuit has a 60 volt battery, and a total resistance of 20Ω , what is the current flowing in the circuit? Use the formula: $I = V/R$

ANSWER PAGE

1. battery
2. negative
3. volts, v
4. current,
5. ampere, a
6. resistance
7. ohm, Ω
8. cells or battery
resistor
ammeter
switch (open)
voltmeter
9. 120
10. 75
11. same
12. voltage
13. sum or (the total of)
14. resistance
15. $V = I R$
16. decrease
17. decrease
18. $I = 60 \text{ v} / 20 \Omega$
= 3 amperes