

**EVALUATING  
ACADEMIC READINESS  
FOR APPRENTICESHIP TRAINING**  
Revised for  
**ACCESS TO APPRENTICESHIP**

**COMMUNICATIONS SKILLS  
IDENTIFICATION OF MAIN IDEA**

**AN ACADEMIC SKILLS MANUAL  
for**

**The Motive Power Service Trades**

This trade group includes the following trades:  
Automotive Service Technician, Heavy Duty Equipment Mechanic,  
Motive Power Parts Person, Transmission Mechanic,  
Truck & Coach Technician, and Truck & Trailer Service Technician

*Workplace Support Services Branch  
Ontario Ministry of Training, Colleges and Universities*

*Revised 2011*

In preparing these Academic Skills Manuals, we have used passages, diagrams and questions similar to those an apprentice might find in a text, guide or trade manual.

**The information in them is not intended to instruct you in your trade. Trade related material is used only to demonstrate how understanding an academic skill will help you find and use the information you need.**

---

---

# COMMUNICATIONS SKILLS

## IDENTIFICATION OF MAIN IDEA

---

*An academic skill required for the study of the  
Motive Power Service Trades*

### **INTRODUCTION**

The **main idea** of anything is its central purpose or point. For example, the main idea of a project such as installing a new engine part is to finish the installation successfully. Everyone who is part of the task contributes to that main idea. Your job may be to fit pieces together, to retrieve materials and to move them to where they are needed, or to read and understand work orders and safety procedures. Every part of the project adds to the main idea of completing the installation successfully.

As you study your trade, you will learn many new skills through reading textbooks and manuals. Identifying the main idea as you examine written material and as you watch a technique being demonstrated will help you sort through information, find what you want, and focus on the exact part that has the ideas or facts that you need. Just as lubrication, ventilation, hydraulics, suspension, and welding are components of the motive power trades, the ability to understand the main idea of a written passage is an essential part of your reading strategies toolbox.

This manual will help you identify the main idea in technical material so that you can recognize what is important. We will look at how technical material is organized and suggest ways to find the main idea in that material. We will examine the following:

- ◆ Titles, headings as guides to the main idea
- ◆ Focusing on the main idea
- ◆ Topic sentences and topic paragraphs
- ◆ Supports to the main idea
- ◆ An approach to reading

### **PART I**

#### **TITLES AND HEADINGS AS GUIDES TO THE MAIN IDEA**

##### ***Organization of Technical Material***

Any technical material you read usually indicates the main idea in the following ways:

- ◆ Titles, headings and short descriptions indicate the main idea of each section.
- ◆ Information is grouped in a logical pattern by topic, chapter and paragraph.
- ◆ The introduction to the topic usually comes first in a section, so you get to the main idea and the purpose of the writing immediately.
- ◆ Individual chapters usually start with basic concepts and move to knowledge that is more detailed after the general introduction to the main idea.

---

**Titles: Finding the Main Idea**

When you need to read technical material, start by looking at the title or name. The title will give you a good general idea of what the material is about.

Compare this to finding equipment in a well labeled drawer. A label makes short work of getting ready to do the job before you even start. Reading labels will help you find information quickly.

**Example:** When you open a drawer labeled *Tools*, you expect to find tools. The label tells you what's inside. Everything in the drawer should be a tool – maybe hammers or wrenches, maybe all kinds of tools. If the label says *chisels*, then everything inside should be a chisel. The label provides an idea of what's there – and what's not there – but it doesn't give you details.

**Titles, headings and sub-headings**

Think of a textbook, manual, chapter, or paragraph as a drawer. A drawer can store equipment and supplies, while a textbook or manual stores information. This information is labeled with *titles, headings* and *sub-headings* so you know what's inside.

Here are headings you might find in a trade manual:

**Lubrication**  
**Principles of Lubrication**  
**Engine Lubricating Systems**

Each heading tells a section is about. The first heading, **Lubrication**, does not tell us any details about what the topic covers. It could be any or all of the following: what lubrication is, how it works, problems and special considerations. But we know that it will be something about lubrication.

The second heading, **Principles of Lubrication**, gives you more information. You know what aspect of lubrication you will learn about – its basic principles. The principles of lubrication is the main idea of this section.

The third heading, **Engine Lubricating Systems**, tells you that you will learn something about the types of engine lubricating systems.

Usually titles or headings illustrate how the material in the text moves from general topics to more specific ones. The main idea of each becomes more focused. Here is an example:

**Hand Tools**  
**Measuring and Layout Tools**

The first heading gives you a huge topic. Compare it to the second heading and notice how the second is more specific. It defines and limits the topic to specific types of tools, giving you a more precise idea of what you'll find.

---

Titles and headings are placed at the top of the text with **bold print** or CAPITAL LETTERS so they're easy to see. Charts and diagrams also have titles, and, often, short descriptions at the bottom or top. Titles provide visual clues that are easy to see and that direct you to the main idea.

A **heading** is a form of title designed to break information into smaller divisions. A **sub-heading** breaks it into even smaller divisions; a sub, sub-heading is smaller still.

Often, a new heading will signal when there's a change in the main idea. It will direct you to the next main idea. Always read titles and headings. They won't help if you skip them.

You'll find a list of chapter titles and section headings in the **Table of Contents** at the beginning of each text or manual. Make sure to check the Table of Contents before you start searching for information.

You might see this Table of Contents in a manual or text. Look at how information is broken into more and more focused topics.

<b>HEAVY-DUTY TRUCKS</b>	Textbook title
<b>Fundamentals of Basic Gearing</b>	Chapter title
Gear Terms	Unit heading
Gear Speed	Sub-heading
Gear Tooth Action	Sub-heading
Relative Gear Positions	Sub, sub-heading

Let's look more closely at how information is organized in this Table of Contents. The same ideas of organization will apply to all texts, manuals or diagrams. Consider these four points about titles and headings:

### One

Observe how much information you get about **main ideas from the titles**.

- The textbook title tells you the kind of information you will find: information about heavy duty trucks.
- The chapter title **Fundamentals of Basic Gearing** lets you know what this chapter will cover.
- Under the chapter title, you see unit headings, sub-headings and sub, sub-headings.

Each tells you what aspect of trucks you will learn about.

### Two

Note that each heading is a new main idea, but each one **stays on the main topic**:

- *Heavy Duty Trucks*, for the text title, and
- *Fundamentals of Basic Gearing* for the chapter heading.

Remember, all the information you read will relate to the larger main idea and all the information in a chapter will relate to the main idea in that chapter (section or unit).

---

### Three

As you read titles and headings, from the textbook title to the sub (and sub, sub) headings, you can see that **topics are more narrowly defined**, (more limited or specific) as they go.

- The textbook title gives you an overall main idea (heavy-duty trucks).
- The chapter title gives you a more specific topic (basic gearing in heavy trucks).
- The unit headings each have a more detailed main idea (gear terms, gear speed, and gear tooth action in heavy trucks).
- The sub-heading divides the topic of gear tooth action in heavy trucks into a more specific topic (relative gear positions).
- Any sub, sub-heading would look at gear tooth position in more and more detail.

By reading the titles and headings, you know quite a bit about what to expect in this chapter. It should all tie together.

### Four

When you read titles, you can see the **order of the information**. When learning a trade, you need to start at the beginning and learn information step-by-step.

- The first chapter, the first textbook, the first manual are the foundation for the second chapter, second textbook and so on.
- The titles list the order in which you will learn.

This order shows you where you are going, and the steps you will take to get there.

### In Brief

1. **The title** indicates what you will read about.
  - a. Everything in this book will be about the main idea – heavy duty trucks.
2. **Chapter headings** identify the parts that form the main idea and show the order in which those parts are presented.
  - a. Every chapter will be about some aspect of heavy duty trucks – basic gearing, hydraulics, general safety and so on.
3. **Headings and sub headings** will identify information contained in the chapter.
  - a. All of the headings in the chapter on safety will tell about the specifics of working safely on heavy duty trucks.

## **PART II**

### **FOCUSING ON THE MAIN IDEA**

#### **Assessing a job**

When you have a job or task to do, you need to be clear about it: What's the job? How big is it? How long will it take? What problems can I see? These are main idea questions.

You need to do the same thing with reading assignments. Ask main idea questions: “What do I have to understand? What am I expected to do at the end? How long will this take?” Then look at the main titles and headings to find out where to start reading.

---

### **The Visual Check**

A **visual check** is a preview of what you will be reading. Looking through a textbook before reading it will help you find information quickly. It provides an overall assessment of the reading material before you begin tackling it. If you are given a reading assignment in **Heavy-Duty Trucks**, look over the book first. These guides will help you identify the main idea:

- The chapter, titles and headings show how the information is organized.
  - Now, look for the heading that refers to the reading you need to do.
- When you find the heading you want, go to that section of the book.
  - Notice how long the passage is and if it is divided into smaller sections.
- Note the diagrams and read information around them.
  - If the information is new and if it looks complicated, you might give yourself more time to spend on it.

### **Seeing A Pattern**

Every document follows a pattern of organization. Information is typically developed from general, large topics to more specific ones as details are added to the main idea. Watch for the pattern, so you understand where you are going and how you are getting there. When you recognize the pattern that a text or manual follows, you will have a pretty good idea of where to look for specific information in the document.

The organization of information will follow one of the following patterns:

- ◆ general to specific,
- ◆ most important to less important or vice versa,
- ◆ problem to solution, or,
- ◆ theory to application.

You will see other patterns too. You may learn why a procedure is important before you learn the steps, or you may learn the importance of each step as you go. Recognize the pattern and then focus on finding the information you need.

### **From main idea to details**

Titles and headings give you a general idea of what you'll find but they don't give details. A drawer labeled *Tools* contains tools but doesn't say how many or what kind. Open the drawer; look at the contents. Take out each tool, or dump them all out. Now, you are getting the details.

### **Keep focused on the main idea**

To get the details of a section of reading material, first do a visual check. After the visual check, read the material, paying attention to what it is telling you. If the material is complicated or new, you may need to split it into smaller portions. It helps to read a difficult part several times.

While you have to pay attention to both the main ideas and all the details that explain it, don't get distracted from the main idea by concentrating too much on a detail.

---

**Example:** You are organizing your tools (main job) and find a drill you lost six months ago. You pick it up, show it to the worker beside you, and wonder how it got here. You have been distracted by a detail from the job you are suppose to be doing.

The same thing happens with reading – you can be sidetracked. Read Passage 1, below, to find the main idea. Use these three steps to guide you.

1. **Use the title as a guide** to the main idea and contents.
  2. **Do a visual check** to look for headings, diagrams and length. Note anything that stands out such as large or bold print. This also gives you some clues as to the main idea.
  3. **Read the passage.** Check the way that each sentence relates to the main idea.
- ❖ *Because this is a working sheet, underline or make notes that will help you. Note that we are examining main idea not shop ventilation.*

### **Passage 1** **Shop Ventilation**

Proper ventilation must be maintained at all times when operating an engine in the shop. A ventilation system must be running, and doors and windows must be open. In addition, personal respirators should be used to remove other contaminants from the air.

Gasoline engines produce exhaust gases that contain something called **carbon monoxide**. Carbon monoxide is a colourless and odourless gas. Inhaling small amounts can cause drowsiness and headaches. Large amounts can be lethal. A closed, one-car garage can accumulate a lethal amount of carbon monoxide within three minutes.

**Toxic fumes** can also be released into the air through solvents that are used to clean engine parts. Warnings on the labels of solvents must be checked and the instructions followed carefully. If using a solvent for an extended length of time, ensure there is plenty of fresh air.

Before answering the questions about main idea, we'll go through the three steps.

#### **Step 1: Use titles and headings as keys to the main idea.**

- The title gives you a guide to the main idea which is shop ventilation.
- You don't know exactly what the information is about.

#### **Step 2: Do a visual check before you tackle the reading.**

- The passage is three paragraphs long.
- Words that stand out are in italics: - *carbon monoxide and toxic fumes*.
- There are no pictures or diagrams.
- The passage seems to develop from general to more specific information.

#### **Step 3: Read the passage carefully.**

- You see that there are eleven sentences and that each sentence refers to or describes something about the main idea: shop ventilation.
- Each sentence contains details that relate to the main idea.

---

When you reach step 3, you are looking for details that relate to the main idea. You open the drawer and study the contents.

**Answer the questions below. Answers are at the end of this skill manual.**

**Questions**

- 1 In paragraph one, what is the main idea?
- 2 What is the main idea in paragraph two?
- 3 Give details from paragraph two that support the paragraph's main idea.
- 4 What is the main idea in paragraph 3?

Once you have found the main idea, the details will answer *what, how, why, when* types of questions. You also expect to find out how all of this relates to you and your trade.

**What's it about?**

Each sentence in Passage 1 relates to the title and topic of shop ventilation; you have confirmed that this is the main idea. You have kept your focus on the main idea. . By going through the process of identifying the main idea of each paragraph, you could now to tell another person what this passage is about. You can also separate the main idea from the details.

Apply this method to find the main idea in anything you read, whether it's for yourself or to explain a design, material or project to a client.

***PART III***  
***TOPIC SENTENCES AND TOPIC PARAGRAPHS***

In technical material, the topic sentence (usually the first sentence) tells you what the main idea is. The other sentences add to this idea. All of the sentences should have something to do with the main idea. Once you are sure about the main idea expressed in the topic sentence, **read the passage carefully** and then ask yourself what it's about. The *usual rule* can help you find the topic sentence, *and* the main idea.

***The Usual Rule:***

1. Paragraphs and passages are set up with a key sentence called a topic sentence.
2. This topic sentence is usually the first one in the paragraph.
3. Topic sentences provide you with the main idea.

In Passage 1, **Shop Ventilation**, the first sentences of each paragraph is a topic sentence.

Paragraph one: Proper ventilation must be maintained at all times when operating an engine in the shop.

Paragraph two: Gasoline engines produce exhaust gases that contain something called **carbon monoxide**.

Paragraph three: **Toxic fumes** can also be released into the air through solvents that are used to clean engine parts.

These topic sentences prepare us for information to come. They say, “This is what we are going to talk about.” The remaining sentences explain or add details to the main ideas.

Below are two opening sentences that show how topic sentences work. These will be the topic sentences in passages 2 and 3, which we will see later. We can expect that anything that follows in the passages should relate to the ideas in these topic sentences.

**Read the topic sentences carefully and answer the questions which follow, even though you haven’t seen the rest of the paragraphs yet.**

**from Passage 2**

Any time a metal is exposed to air, the oxygen in the air combines with metal to form a chemical film over the metal called the *oxide* of the metal.

**from Passage 3**

Oxides are important in that the characteristics of the oxide determine many of the characteristics of the metal.

**Questions**

1. What is the main idea?

**from Passage 2**

- a) air and metal
- b) oxides of metals
- c) chemical films

**from Passage 3**

- a) characteristics of oxides
- b) the importance of oxides in metal
- c) how oxides determine metal characteristics

**Before you check the answers at the end of this skills manual, read Passages 2 and 3, below.** Do you need to change your answers for 1 or 2? Do the first sentences work as the topic sentences? Why or why not?

**Passage 2**

Any time a metal is exposed to air, the oxygen in the air combines with metal to form a chemical film over the metal called the *oxide* of the metal. A familiar example of an oxide is the rust that forms on uncoated iron and steel (iron oxide). Similarly, the green chemical often formed on copper is an oxide of copper.

**Passage 3**

Oxides are important in that the characteristics of the oxide determine many of the characteristics of the metal. Iron oxide (rust) forms quickly and is porous and flaky. Because of the porous quality, moisture is allowed to seep through and form more oxide underneath. This causes flaking, which

---

exposes more metal that will then form more oxide. Eventually, this action will eat through the metal, and is why plain steel is poor metal to be exposed to corrosive conditions.

Does the *Usual Rule* apply? **Yes**, these work as topic sentences:

- They give the main idea and the other sentences build information from that idea.
- They combine, in a logical order, to develop information on oxides in metal.
- The usual rule applies.

**NOTE:** *If you aren't sure about the main idea after reading the first sentence in a passage, go on to the second or third sentence. The main idea and direction of the passage should become clearer as you proceed. One idea or topic should emerge as the main idea.*

### **Topic Paragraphs**

Longer passages begin with a **topic paragraph**. They act like topic sentences. They tell you what the whole passage or section is about. Watch for introductory paragraphs that prepare you for a large piece of information. They come first, are often short and give you the main idea and purpose of what you are going to read.

### **In Brief:**

1. Titles and headings give you some information about the contents. They tell you what the textbook or passage is about, in other words, what the main idea is.
2. The next step is visual; you can “see” what to expect, and where the information fits in with the rest of the material.
3. When you read each paragraph, identify the topic sentence, which gives the main idea of that paragraph.
6. The other sentences should add information or details to the main idea.
4. Identify the topic paragraph when you read a chapter or a longer section.
  - The other paragraphs should add information to the main idea.

## **PART IV**

### **SUPPORTS TO THE MAIN IDEA**

*Supports to the main idea* are the individual items that give us detailed, specific information. In terms of the main idea, supports may do any of the following:

- ◆ define or explain it,
- ◆ describe how it works,
- ◆ illustrate how it operates,
- ◆ show the steps, or
- ◆ show the results.

---

### **Identifying Supports To The Main Idea**

Read Passage 4. See if the main idea is placed first – and what it is. Do the supports follow with details about the main idea?

#### **Passage 4 Lubrication**

Lubrication is relied upon heavily in the metal working industries. Used correctly, it reduces friction between components and increases component life by reducing wear.

Oil is the most common kind of lubrication. When oil is applied to two surfaces in contact, a film is formed. This film fills depressions and covers projections on both surfaces. This reduces friction and results in a sliding between the layers of oil within the film, a term known as **fluid friction**. Examples of oil lubricating systems are once-through systems, enclosed systems, splash lubrication, oil bath lubrication, and oil mist lubrication.

We should find the topic sentence in the first paragraph. It should give the main idea and prepares us for supports to the main idea. The supports might define or expand the main idea. They will describe a method, illustrate with diagrams or photos, or provide examples. Let's look at paragraph one to see if it works this way.

#### **Paragraph one**

Sentence one states: *Lubrication is relied upon heavily in the metal work trades*. The main idea here is lubrication in the metal working industry – this is the topic.

Sentence two tells us the benefits of lubrication (**why** we would use it): When used correctly, lubrication reduces friction between components and increases component life by reducing wear.

#### **Paragraph two**

Paragraph two should continue the main idea (lubrication) with details. The first sentence gives a type of lubrication: oil. This tells us that the main idea in paragraph one is followed by more detailed information about oil in paragraph two. Each supporting detail adds information about the main idea. We learn:

- that oil is the most common lubricant,
- what happens to oil when applied,
- the result: *fluid friction*, and,
- examples of oil lubricating systems.

This passage about lubrication shows a common pattern used in technical writing.

1. The **title** communicates the topic in brief.
2. The **topic sentence or paragraph** communicates the main idea in expanded form. The sentences that follow add details.

## Diagrams

Many reading passages will direct you to look at diagrams, illustrations or photos. These figures show you what something looks like or how it works. They relate to the main idea but they also add details. If a passage tells you to *See Figure 1*, you can expect a diagram, chart or table.

We'll use a simple diagram, Figure 1 below, to demonstrate how diagrams support the main idea. Look at the diagram to understand the main idea (lubrication of piston and rings via an oil-spurt hole). Read the text below the diagram for both main idea and supports.

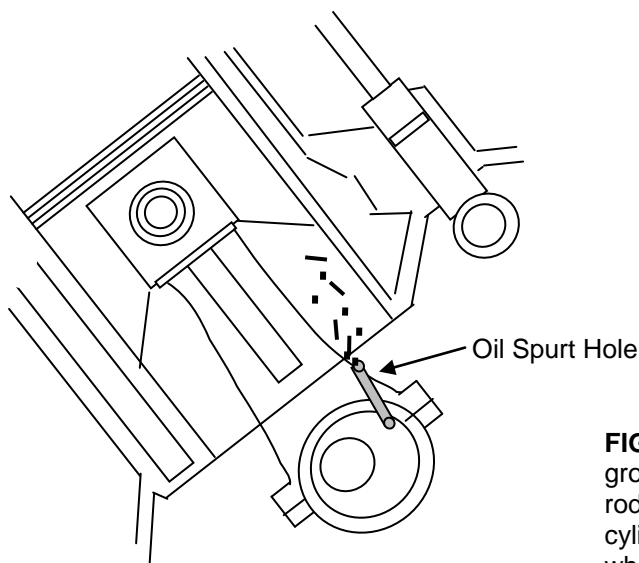

**FIGURE 1:** Many engines have small matching grooves or an *oil-spurt hole* in each connecting rod. This opening provides additional piston and cylinder wall lubrication. A spurt of oil sprays out when the hole in the rod aligns with the crankshaft-journal oil hole once each revolution.

By studying the diagram, you can see how an oil-spurt hole works. The diagram gives support to the main idea and illustrates details you may not understand from reading the text alone.

### ***Steps to Supports***

Narrowing in on the supports to the main idea is like starting a job.

1. First, you need to ask main idea questions:
  - a. What is the task (the job or the reading)?
  - b. How long will it take?
  - c. Where is it located?
  
2. Next you need to look more closely at the details and ask specific questions:
  - a. **What** manuals do I use?
  - b. **What** procedures and materials do I use?
  - c. **What** order will I use for the project and **why**?
  
3. Proceed carefully.
  - a. Stay focused on the purpose of the task.
  - b. Make sure that each part helps to accomplish the main purpose.

---

## Getting the information you want

Getting what you want, whether you are reading for information or doing a job, involves seeing the big picture and then narrowing in on details. In this way, you become knowledgeable, and you can make informed decisions. If you use this approach when you read for your trade, you will get the information you need to understand an aspect of your trade.

### In Brief: The Three Steps

**Step 1:** See the big picture: Look at the title.

**Step 2:** Get a better focus: Use the visual check to preview the reading.

**Step 3:** Look more closely: Read for details.

**Passage 5** might be found in a section of a text book on *Trade Science*. As you read it, apply the three steps.

#### Passage 5

##### Physical States of Matter

Matter exists in one of three physical forms or states: solid, liquid or gas. Substances change states without changing their chemical structure. In appropriate conditions, solids melt into liquids or vaporize, liquids freeze to solids or vaporize into gases, and gases condense into liquids.

When water changes its physical states the make-up of the molecules remains the same. Molecules of frozen water (ice) still contain two hydrogen atoms and one oxygen atom, chemically combined. Steam also contains these types of molecules. It is mostly a change in temperature that causes changes in the different physical states. Because of this, water can be made to return to a previous state by changing surrounding physical conditions.

**Step 1: See the big picture.** In a passage with the title, **Physical States of Matter**, you expect:

- Definitions and descriptions of the physical states.

**Step 2:** Get a better focus **by previewing** the passage.

- You see it has two paragraphs.
- One word, *ice*, is in parentheses ( ). Pay attention to signals such as parentheses that indicate explanation, definition or useful details.
- Find the topic sentence in paragraph one: *Matter exists in one of three physical forms or states: solid, liquid, or gas.*
- In paragraph two, the topic sentence refers to a specific aspect of physical changes of state: *When water changes its physical state, the make-up of the molecules remains the same.*
- Sometimes a diagram or table will be part of a passage. Make sure you always look at the text, charts, tables, and diagrams. Any details found in the diagrams will help you to follow the details in the reading. Also note if any information is highlighted.

**Step 3: Read carefully for details.**

- Check the supports (details) to see if they are guided by the title and the topic sentences.
- Look to understand the details which answer **what**, **how**, **how much** and **why** questions.

---

## Make information accessible

When you need to understand a piece of technical writing, write down all the main ideas and a list of the supporting details. We suggest making a list of supporting details for two reasons:

1. You need to identify and find the details before you can work with the information.
2. You need to break down information, especially if it is long, complex, and filled with details.

### *Types of Supports*

When you recognize the type of support being used, it should help you find what you want quickly. Supports to the main idea include but are not limited to the following:

1. **Examples:** Examples take you from what you know to new knowledge. They give you a clearer picture of what something is, or what it includes or how it works. The passage usually signals an example.

*For example*, a four-stroke cycle engine includes: intake stroke, compression stroke, power stroke, and exhaust stroke.

*Example:* Ethylene glycol is an antifreeze because it lowers the freezing point of water

Watch for examples that do not have the word *example* as a signal. The above sentence could be re-written as follows:

Antifreeze is a material, such as ethylene glycol, that is added to water to lower its freezing point.

2. **Order of Ideas:** Order of ideas (sequence) describes the parts or steps in a piece of information or a process. It is a common type of organization used in technical materials.

Usually technical information is presented first in a general introduction and is followed by details that are more specific. The opening or introduction may outline the content, the application and the importance of the information.

The example below explains something about the relationship between drilling and reaming. The opening sentence introduces the topic with a general statement about location. Then follow instructions that are more specific.

**Example:** Reamers follow the location of the drilled hole. Ensure that the drilled hole is located accurately before reaming. Holes to be reamed must be drilled undersize to allow the reamer to cut it to size. The amount of material left for reaming, depends on the type of reamer used....

Here is a step-by-step example with no introduction:

**Example:** Place the wrench on the bolt head (or nut), so the movable jaw faces the direction the fastener is to be rotated. Adjust the thumbscrew so the jaws fit the bolt head snugly. Then, pull the wrench to rotate the bolt.

---

Directions and instructions will start with the first step. Look for numbers or letters; also, look for lists, or steps. Look for words such as *to begin with*, *first...second*, *then/next*, *before...after*, *in the same way*, *finally*. Remember, there is a reason for the order even if you don't know what it is.

3. **Definitions:** If the topic introduces a new concept or a technical word, you need an explanation of what it is before you know what it does. Technical terms are defined so you can understand the new word. Take note of special print or marks that are designed to get your attention.

**Example:**

*Lapping* is the process of fitting one surface to another by rubbing them together with an abrasive material between the two surfaces.

*“Stability”* is a relative measure of the handling characteristics that provide the desired and safe operation of the vehicle during various manoeuvres.

The definition may state what something is or what it does. Parentheses ( ) may give you the correct, technical term, clarify a term or direct you to a diagram.

**Examples:**

A material used to restrain or hinder some unwanted action, like rusting, is called an **inhibitor**.

The bolster plate (or upper coupler) is the flat, load-bearing surface under the front of a semi-trailer that rests firmly upon the fifth wheel when coupled.

The fasteners used to secure the connecting rod to the piston (piston pins) are made of casehardened steel and ground to exact size.

Definitions tell you what technical terms mean:

**Example:**

When a battery is improperly charged or allowed to remain in a discharged state for a length of time, an abnormal amount of lead sulfate will collect on the plates. A battery in this condition is said to be *sulfated*.

Look for definitions and make notes. These are the words of your trade and you need to make them part of your new vocabulary.

4. **Comparison and Contrast:** Comparisons show similarities and differences while contrasts show differences only.

This is done to help explain, define and expand your knowledge of relationships. The underlining in the example below illustrates how this is done:

---

**Example:** Base your working loads on “Safe Load Ratio” **not** on the “Break Lbs”. The strength ratings are based on tests at room temperature; rope strength decreases with an increase of temperature.

Comparison of products will show you their different qualities and applications.

**Example:** With *updraft carburetors*, the air velocity must be high, so small passages must be used in the carburetor and manifold. Conversely, *downdraft carburetors* operate with lower air velocities and larger passages.

Look for words such as *in contrast, some ... others, whereas, yet, on the other hand*.

**5. Cause and Effect:** Cause and effect explains relationships. Why did my drill overload? What caused it? Can I take steps to prevent it from happening next time? Look for supports that explain the relationship between cause and effect.

**Example:**

Flattening the cutting edge prevents the drill from biting into the material too rapidly and overloading the drill.

An understanding of cause and effect gives you the tools to explain a procedure, product, or principle to a customer.

## ***PART V*** ***AN APPROACH TO READING***

### ***Know What You Want***

What you want from a reading affects how you approach it. If you know exactly what you need, you might go over the contents quickly until you come to the information you want. Then you should carefully examine the details concerning that topic.

You may need instructions about using a drill press, an explanation of how stress affects sheet metal, or the details about a certain ignition system. If you are reading for a specific reason, you look for information related to your aim and pay less attention to details that don't seem related. This is a logical and economical approach to reading for a purpose. Below are some suggestions for getting what you need from a reading:

- ◆ Make notes while you read, detailing the main points.
- ◆ Use your own words to repeat what you have read.
- ◆ Try stating the main idea.
- ◆ Give the passage a title.
- ◆ Can you tell someone else what the passage is about in a few words? If you can, you've identified the main idea.

To understand a passage, you need to know its main point and its details. You should be able to say, “This tells me the difference between those two parts.” and, “This explains why I need to

lubricate.” If you can’t, you need to reread the passage to find the main idea. Then look again at what supports do: They relate to the main idea but they also add details to our understanding.

### **Troubleshooting the System (Getting lost – and found again)**

You think you have a clear sense of the main idea. You know what it's about. But, as you get further into the material, you start feeling lost.

Check:

- *Maybe you weren't on the main trail at all.* If the sentences don't seem on topic, rethink the main idea.
- *Maybe the paragraph doesn't have a clear topic sentence.* You can still find the main idea by looking at what all the sentences are about. Try to identify one word or phrase that seems to be the theme of the paragraph and develop the main idea from this.
- *Maybe you're on the main trail but have strayed a little bit off it.* Again, this will send you back to the beginning. As you go back through the sentences, you may find a confusing part and realize, “Here's the spot that baffles me.” You can identify the main idea, but a sentence or part of a chart contains details you don't understand.

If you get the main idea but need to clarify some of the details, the first step is to identify the problem. It may be new vocabulary or words used in unfamiliar ways, technical terminology, or a math formula.

### **Begin to solve the problem.**

1. Can you look up the new words?
2. Can you find a technical definition?
3. Should you get extra help with the math?

Sometimes a writer assumes you know a concept or theory, and has left it out. This makes your job tough. You may need help from an instructor, a different textbook or another student. Remember, if you can find the problem, you can fix it.

### **Read out loud**

If you are stumped by a passage, try reading it out loud. Sometimes you discover that you have been reading one word wrong the whole time. Reading aloud may help you solve the puzzle. Sometimes you can “hear” a problem better than you can “see” where the problem exists.

### **Complex passages**

The main idea may jump out at you in short, familiar readings. In complex paragraphs with math formulas, technical terms, and scientific information, you may find the main idea buried. Read the section in pieces; ask questions as you go, underline and make notes. You might need to read parts of the passage several times to understand how the details relate to the main idea.

---

## Application

Your test of understanding is the ability to explain something to someone else. Imagine you have to explain an estimate to a client. Where do you start? Start with the main idea.

1. **The main idea:**
  - It may be the difference between tune up and a part replacement.
  - You can give an overview and any problems you might expect.
2. **The supports** may include a variety of information. The details in the explanation depend upon how much your client wants to know:
  - Do they need all the details?
  - Can you show them a diagram?
  - Do they need to understand why the parts are unavailable or are expensive?

Just as a writer chooses details to support the main idea and purpose, so do you. You can explain this – or anything else – by starting at the beginning (main idea) and work through the details. You will use definitions, examples, comparison, and cause and effect details that relate to the situation. You will be practicing your skills and demonstrating your expertise.

## CONCLUSION

As you read ask yourself, "What is this about?" If you can answer the question, you understand the main idea. If you can't answer it, go back and follow the steps to identify the main idea.

Build your skills from the base up. As you move to concepts that are more difficult, either in reading or in the complexity of a job, the skill of separating the main idea from the details still holds. The goal will remain the same: understanding the main task and all the details necessary to get you to a successful completion.

Work to understand how the details relate to the main idea. This may take longer, but if as a result, you get the effects you want, the time is well spent. When you understand the purpose of a passage, you find what you need, and, most importantly, find what you are supposed to learn.

## Summary

1. **Notice how your trade / technical material is organized.** Do a visual check of the passage for length, for highlighted information and diagrams. Look for the patterns.
2. **Focus on the main idea when you start.** Identify the main idea through the title, the topic sentence, and find the supporting details that expand the main idea.
3. **Use the supporting details** to help you sort out the main idea. The supporting details answer questions such as how, what, why, where, when, and in what order.

- 
4. **Understand the types of details** found in technical writing. The supporting details give examples, order (sequence) of steps or ideas, definitions, comparisons and contrasts, and causes and effects.
  5. **Use an organized approach** to reading. Understand why you are reading so that you focus on the details you need. Make sure you also find what you are required to learn.
  6. **Translate what you have read into your own words** as though you were explaining it to someone else. Work from the main idea through to the details.
  7. **If you get lost, stop.** Find out where you got lost and try to identify the problem: Is it main idea, technical vocabulary, a math formula?
  8. **Accept that picking out supports to the main idea and listing information takes longer than just reading.** The results – identifying, finding and understanding the information you read – are essential to your trade success.

---

**ANSWER PAGE**

**PART II Passage 1, Shop Ventilation**

1. The main idea of paragraph one is the importance of maintaining ventilation in a shop when operating an engine.
2. The main idea of paragraph two is why good ventilation is necessary in the shop – because carbon monoxide, a dangerous gas, is produced by the engine.
3. Details from paragraph two include the facts that carbon monoxide is colorless and odorless and that inhaling large amounts can be lethal.
4. The main idea of paragraph three is that cleaning solvents can also cause toxic fumes.

**PART III Passage 2 and Passage 3**

**from Passage 2:** What is the main idea?

- b) oxides of metals

**from Passage 3:** What is the main idea?

- c) how oxides determine metal characteristics.