

**EVALUATING  
ACADEMIC READINESS  
FOR APPRENTICESHIP TRAINING**  
Revised for  
**ACCESS TO APPRENTICESHIP**

**SCIENCE SKILLS  
BASIC ELECTRICAL CIRCUITS**

**AN ACADEMIC SKILLS MANUAL  
for**

**The Small Motors Service Trades**

This trade group includes the following trades:  
Marine & Small Powered Equipment Mechanics,  
Motorcycle Mechanics, and  
Small Engine Mechanics

*Workplace Support Services Branch  
Ontario Ministry of Training, Colleges and Universities*

*Revised 2011*

In preparing these Academic Skills Manuals we have used passages, diagrams and questions similar to those an apprentice might find in a text, guide or trade manual.

**This trade related material is not intended to instruct you in your trade. It is used only to demonstrate how understanding an academic skill will help you find and use the information you need.**

---

---

# SCIENCE SKILLS

## BASIC ELECTRICAL CIRCUITS

---

*An academic skill required for the study of the  
Small Motors Service Trades*

### **INTRODUCTION**

Electrical current is created by the flow of electrons moving through a conductor. As electrons move along a conducting wire, they can be used to do electrical work such as starting an engine or lighting a bulb.

Electricity comes from several different sources. A simple battery produces a direct current that results from chemical reactions that take place inside the battery. The electrical power used in homes and factories is generated in power stations and then travels long distances over transmission wires as an alternating current. The electricity used in vehicles to start the engine, fire the spark plugs and operate the lights is generated by a battery that produces a direct current. The alternator that supplies electricity to keep the battery charged relies on electromagnetic induction to produce an alternating current.

This skill manual looks at the principles involved in an electrical circuit:

- ◆ How atomic structure creates electricity
- ◆ Creating a potential difference
- ◆ Sources of electricity
- ◆ A simple direct current circuit
- ◆ Ohm's Law
- ◆ Circuit diagrams
- ◆ Circuits connected in series
- ◆ Circuits connected in parallel
- ◆ Electromagnetism and induced current

### **HOW ATOMIC STRUCTURE CREATES ELECTRICITY**

An electrical current is created when electrons move through a conductor. As electrons move along a conducting wire, they can be used to do electrical work. Electricity can be used in many applications, from running a power tool to sending a signal through a cable.

Electrons and protons, both subatomic particles, have a property called charge. Electrons have one kind of charge, called a **negative** charge, and protons have the opposite kind of charge, called a **positive** charge. A negative charge is indicated by a minus sign (-) and a positive charge is indicated by a plus sign (+).

---

Charged particles react to other charged particles in specific ways:

- ◆ An electron and a proton, having opposite charges, attract each other.
- ◆ Two particles with the same charge, such as two electrons, repel each other.
- ◆ The force of these charges causes free electrons to move away from other electrons.
- ◆ At the same time, free electrons move towards protons.
- ◆ We say ***opposite charges attract and like charges repel***.
- ◆ The reaction that takes place between charged particles is important in electrical generation.

Protons are held tightly in the nucleus of an atom but electrons are free to move. Since all electrons have the same kind of charge, the repulsive force of their charges causes them to move as far from each other as possible. When electrons move in a wire, they carry their negative charge with them as they conduct electricity.

When more electrons than protons build up in an area such as a metal plate, the plate becomes negatively charged. If there are fewer electrons than protons on another metal plate, this plate becomes positively charged. Differently charged plates generate the current in a dry cell battery.

### ***CREATING A POTENTIAL DIFFERENCE***

When a negative charge is created on a metal plate, an outside source of energy (work) has to be supplied to move electrons closer together. In the same way, energy has to be supplied to remove electrons from the positive plate in a battery. The work done to create the negative and positive plates is stored as potential electrical energy that can be used to do electrical work in a circuit.

An electrical circuit consists of:

- an area of high concentration of electrons,
- an area of lower concentration,
- a wire connecting the two areas and
- a load or resistance such as a light bulb.

Electrons in a circuit flow in a current from an area of high concentration of negative charge to an area of lower concentration. A current is created as the excess negative electrons seek to establish equilibrium (a balance) by flowing to where there are fewer electrons.

We can say electrons are pushed away from the area of negative charge by the force of repulsion between the crowded electrons, and pulled towards the area of positive charge by the force of attraction. This force is called an ***electromotive force (emf)***.

The difference in concentration of electrons at the two ends points of the connecting wire is called a ***potential difference***. This potential difference is called the ***voltage (V)*** of a circuit. Work was done originally to create a potential difference. Now the potential difference can be used to do electrical work.

---

## **SOURCES OF ELECTRICITY**

Electricity comes from several different sources. The electrical power used in home and at work is generated as an *alternating current (ac)*. In an alternating current, the electrons move back and forth, changing direction many times a second. Cordless equipment uses electricity generated by a battery. The electricity produced by a chemical battery flows as a *direct current (dc)* power source. In a direct current, the electrons flow in one direction.

### **Direct Current**

One of the first types of useful electrical energy came from the conversion of chemical energy into electrical energy in a dry or wet cell. A battery is made from a series of cells connected together. It develops its electrical potential through chemical reactions between different substances found inside the battery. This electrical energy is used as a direct current to run wireless electronic equipment, cordless power tools and many other devices. In a vehicle, a lead-acid battery is used to start the engine and run equipment such as the lights and radio.

When we start a vehicle, the chemical reaction between sulphuric acid and lead provides the power to turn the ignition switch. When we drive, the chemical reaction in the battery is reversed through the energy provided by the alternator, so the acid and lead are ready to react again. The battery is recharged.

If we leave a device like the lights on for too long when the vehicle is not running, the battery will go dead as the chemical reactions gradually stop occurring. Once the chemical reactions cease, no more electrons are supplied to the conductor to run through the circuit. There is no longer any current.

### **Alternate Current**

Most electricity is mechanically generated by water power, steam turbines or through nuclear reactions. This electricity is supplied as an alternating current, not a direct current. An alternating current flows in one direction for a short time, then stops and flows in the other direction. This happens very rapidly. The alternating current generated in large power stations and in alternators is a result of the effects of a magnetic field on a current.

There is a close relationship between electricity and magnetism.

- A magnet generates a current when a wire is moved through the magnetic field or when the magnet itself is rotated back and forth.
- Similarly, a current flowing through a wire creates a magnetic field around the wire.
- These two reactions are used in the electromagnetic generation of alternating current.
- A potential difference is created in the conductor.
- When a potential difference occurs and electrons are free to flow in a closed circuit, a current is created.
- The current resulting from a magnetic field is called an induced current.

## A SIMPLE DIRECT CURRENT CIRCUIT

A simple direct circuit consists of the following:

- a source of electromotive force (a difference in potential),
- a conductor along which a current flows,
- electrical devices, called loads or resistors, that use the potential energy of the current to do work, and
- a switch to turn the circuit on and off (to start and stop the flow of electrons).

Because the simplest generator of electricity is the single cell, it is a good system to examine in order to learn how a circuit works. In a simple cell, two plates with opposite charges are separated by an insulator. The work required to create these differently charged plates can be done by chemical reactions that occur in the cell. See Figure 1.

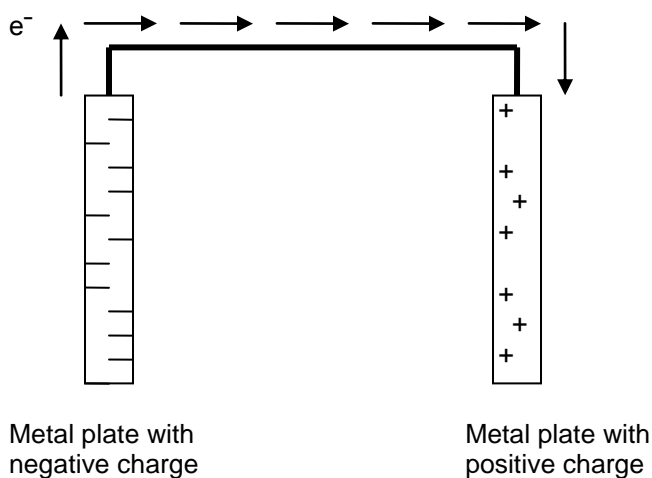

**FIGURE 1: Creating An Electric Current**

The breaking of chemical bonds releases energy. This energy is used to move electrons to the negative plate, resulting in an area where excess electrons are crowded close together. It takes energy to move electrons to where there are already many negative charges; this energy is stored as potential energy which can be used as a source of electrical power.

### Voltage

Work has been done to move these electrons against the normal distribution of charges in the electrical field. This results in a potential difference between the negative and positive plates. *This potential difference is a measure of the amount of electrical work that can be done by the flowing electrons or charges when the two plates are connected.*

- If the plates are connected by a conducting wire, electrons will flow from the negative plate with its excess of electrons, to the positive plate with its fewer electrons.

- If the plates are not connected, the maximum potential difference exists between the plates. This is because all of the electrons that have been moved against the electrical field are still located on the negative plate.

This potential difference is referred to as the electromotive force (emf or  $E$ ) or the voltage ( $V$ ) of the cell. The voltage refers to the amount of work the circuit can potentially do. The unit of electromotive force is the **volt** ( $v$ ). Voltage is measured using a voltmeter.

### Current

As electrons flow through the wire conductor towards the positive plate, they create a current. An **electric current** ( $I$ ) is the rate of flow of charge or electrons past a given point in an electric circuit.

- It is similar to counting the number of electrons that flow past a point in a certain amount of time.
- Current equals charge divided by time.

The unit of current is the **ampere** ( $a$ ). It is measured by the ammeter.

### Resistance

Even good conductors offer some opposition to the flow of electrons.

- Electrical devices or loads on the circuit such as a light bulb, offer a great deal of opposition.

This opposition to the flow of electricity is called **resistance** ( $R$ ). The unit of resistance is called the **ohm** ( $\Omega$ ). It is measured by an ohmmeter.

### Power

The rate at which electrical energy is delivered to do work is called the **electrical power** of the circuit. It is measured in units called **watts** ( $w$ ) or **kilowatts** ( $kw$ ). Power is calculated by multiplying voltage times current.

- Our electrical bill is calculated on the kilowatt hours of power we use.

### In Brief:

A simple direct circuit consists of the following:

- ◆ differently charged metal plates used as a source of electromotive force (a difference in potential),
- ◆ a conductor along which a current flows,
- ◆ a switch to turn the current on and off (to start and stop the flow of electrons) and
- ◆ electrical devices, called loads or resistors, that use the potential energy of the current to do work.

### ***OHM'S LAW***

In a direct current cell, there is a close relationship between voltage, current and resistance. A scientist named Georg Ohm studied electric circuits and found that the value of the resistance of

a circuit is equal to the voltage divided by the amount of current. This ratio is known as **Ohm's law**.

Ohm's law states: *The resistance of the circuit is equal to the ratio of the voltage to the current.*

In the formula expressing this relationship we use:

R = resistance, expressed in ohms ( $\Omega$ )

V = voltage, expressed in volt (v)

I = current, expressed in amperes (a)

The formula for Ohm's Law is: resistance =  $\frac{\text{voltage}}{\text{current}}$

$$R = \frac{V}{I}$$

To find the voltage in a direct current cell: voltage = current  $\times$  resistance

$$V = IR$$

To find the current in a direct current cell: current =  $\frac{\text{voltage}}{\text{resistance}}$

$$I = \frac{V}{R}$$

If you know two quantities in the formula, you can find the third. If you are given the voltage and the resistance of the circuit, you can find the current.

**Example:** If the voltage is 12 volts and the total resistance is 24 ohms, what is the current?

Use the formula that shows "I" on the left.

$$I = V/R$$

$$I = 12\text{v} / 24 \Omega$$

$$I = .5 \text{ a}$$

**Example:** If the current is 6 amperes and the voltage is 60 volts, what is the resistance on the circuit?

$$R = V/I$$

$$R = 60\text{v} / 6\text{a}$$

$$R = 10 \Omega$$

**Example:** If the current is 10 amperes and the total resistance is 12 ohms, what is the voltage?

$$V = I R$$

$$V = 10\text{a} \times 12 \Omega$$

$$V = 120\text{v}$$

Because resistance, voltage and current are closely related, if you change any one of these quantities, at least one of the other quantities also changes. If you put a battery of lower voltage in a circuit and the resistance remains the same, the current will decrease. If two circuits have the same voltage, but one has more resistance, the current will be less in the circuit with more resistance.

### In Brief:

Ohm's law explains the following relationships in a circuit:

- Increasing voltage results in increased current if resistance stays the same.
- Decreasing voltage results in a decrease in current if resistance stays the same.
- Increasing resistance decreases current if the voltage stays the same.
- Decreasing resistance increases current if the voltage stays the same.

### CIRCUIT DIAGRAMS

Conventional symbols such as those shown below and in the diagrams that follow are used to represent the components in circuit diagrams. These symbols are used to make diagrams of simple direct electrical circuits. In your work, you will learn to read circuit diagrams that are quite complicated. To explain the basic principles, we will look at simple examples of circuit diagrams.

Here are a few symbols used in circuit diagrams:

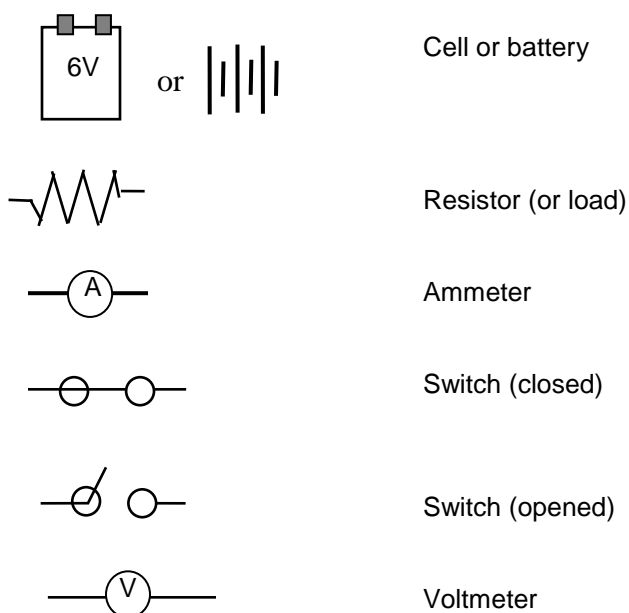

Circuit diagrams are helpful in understanding and solving different problems concerning circuits. Figure 2 is an example of a circuit diagram.

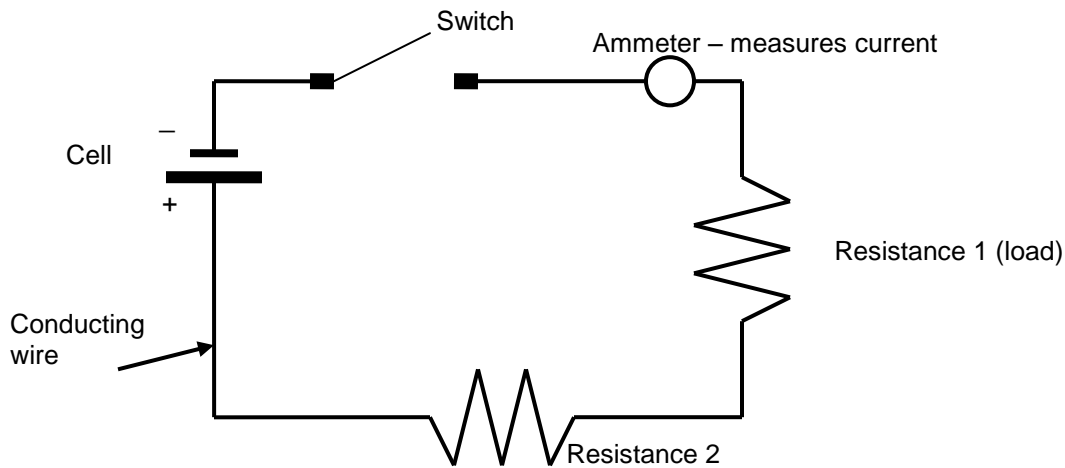

**FIGURE 1: A Simple Direct Circuit**

This circuit has a source of voltage, a conducting wire, a switch, two resistors and a device to measure current.

### ***CIRCUITS CONNECTED IN SERIES***

Appliances that run on electrical current need to have the right amount of voltage to work properly. A flashlight that runs on 1.5 volts would burn out if connected to a 6 volt battery, while a car connected to a 6 volt battery wouldn't get enough current to start.

#### **Cells in Series**

A cell creates a certain amount of energy, depending on its voltage or emf, that can move a certain amount of current around the circuit. If one cell can't provide an adequate amount of voltage, cells can be combined in series to provide the amount required. Two or more cells connected together are called a **battery**. Cells can be combined in series, in parallel, or a combination of the two.

Cells can be connected in series to provide more voltage:

- When cells are combined in series, the negative terminal of one cell is connected to the positive terminal of the next cell.
- The negative terminal of that cell is connected to the positive terminal of the cell next to it.
- The negative terminal of the last cell in the series is connected to the circuit wire, which completes the circuit by connecting back to the positive terminal of the first cell.

Each cell adds to the potential electrical energy or voltage, because each pumps up the energy level. Each cell helps create a greater potential difference between the two plates. *The voltage in a circuit with cells connected in series is the combined voltage of each cell added together.*

Because cells connected in series are one continuous circuit, the same amount of electricity or current must flow through each cell. *The current in a circuit that is not divided into parallel*

branches must be the same everywhere, because the same amount of current is flowing throughout at the same rate.

### Resistances in Series

The amount of energy used up in the circuit is called the **voltage drop**. A voltage drop is the difference in voltage before and after the current moves through a resistance.

Just as cells can be connected in series or in parallel, so can resistances. If resistances are connected in series, the total resistance of the circuit is equal to the sum of all the different resistances.

If a battery provides 12 volts to the circuit, the resistances should use up all 12 volts before the current reaches the positive terminal of the battery. If there is one resistance, it should use about 12 volts of energy. If there are several resistances connected in series, each resistance will use less than 12 volts but the total voltage drop should equal 12 volts.

In other words: *The sum of all the individual voltage drops is equal to the total voltage drop. The voltage drop across the circuit is equal to the original voltage of the battery.*

- If there is one resistance in a circuit, it should use up all the voltage as the current moves through it.
- If there is more than one resistance, all the energy should be used up by the time the current flows through the whole circuit.
- If the circuit is not connected (the switch is open), there is no voltage drop because no current is flowing.

Figure 3 shows a circuit where both the cells and the resistances are connected in series.

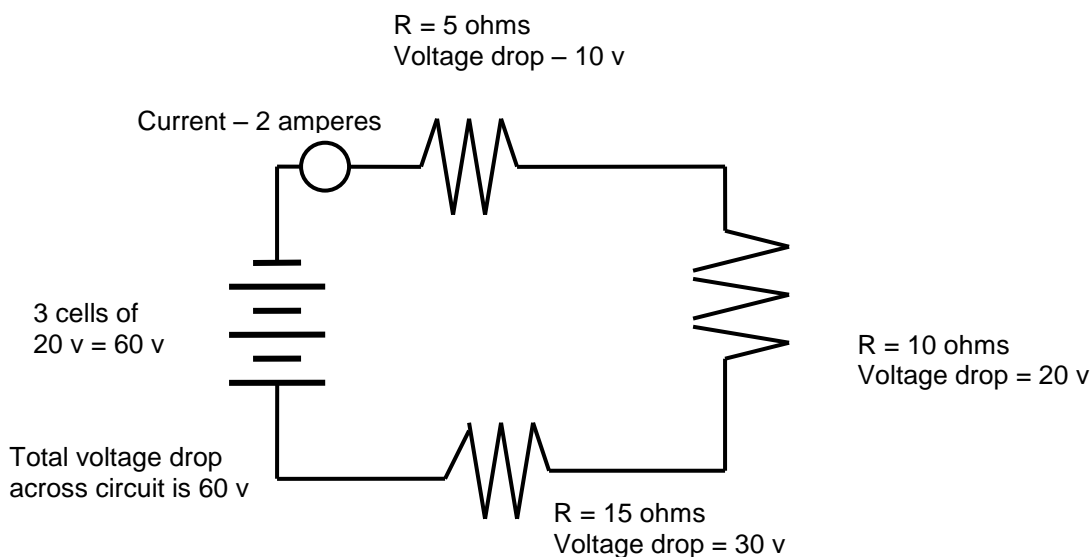

**FIGURE 3: Circuit with Both Cells and Resistances in Series**

In Figure 3:

- Three cells, each with 20 volts, are connected to make a 60 volt battery.  
 $20\text{v} + 20\text{v} + 20\text{v} = 60\text{v}$
- Three resistors are connected in series, equaling a total of  $30\ \Omega$ .  
 $5 + 10 + 15 = 30\ \Omega$
- The voltage of the battery is 60 volts, so the total voltage drop across the circuit is 60v.
- Current is equal to voltage, 60v, divided by resistance, 30 ohms, which equals 2 amperes.  
 $60\text{v} \div 30\ \Omega = 2\text{a}$

### **In Brief**

In a circuit connected in series:

- The voltage of the circuit is equal to the sum of the voltage of each cell;
- The amount of current flowing in the cells, in the wire and in the resistors is the same;
- The total resistance is equal to the sum of the individual resistances;
- The sum of the individual voltage drops across each resistor equals the total voltage drop;
- The total voltage drop across the circuit is equal to the voltage of the battery.

## ***CIRCUITS CONNECTED IN PARALLEL***

### ***Cells in Parallel***

Circuits connected *in parallel* have all the negative terminals connected together by wire. The last negative terminal is connected to the external wire that carries the electrons around the circuit. This wire then connects to the positive terminal of the first cell, which is connected to the positive terminals of each of the other cells.

This has the same effect as a single cell with a large surface area.

- The larger surface area of the two plates doesn't create more electromotive force (voltage) because the proportion of opposite charges remains the same.
- For this reason, each cell connected in parallel should be at the same voltage, just as if it were one large cell.
- However, a battery connected in parallel can produce more current (more electrons flowing per second) because of the bigger surface area of the combined cells.
- The amount of current (number of electrons flowing) produced by the surface area of each cell is added together to get the total current in the circuit.

*The total current of the cell is equal to the sum of the individual currents contributed by each cell.*

Making the surface area bigger only increases the total amount of current. It doesn't increase the amount of potential difference, so the voltage doesn't increase. Each cell in a parallel series must be at the same voltage, just as if it were one large cell.

In a circuit connected in parallel:

- The voltage of the circuit is equal to the voltage of each individual cell, which must all have the same voltage.

- The total current of the circuit is the sum of the individual currents provided by each cell. Since each cell has the same voltage, the current supplied by each cell will be the same.

These relationships are seen in Figure 4, a diagram of a circuit with cells connected in parallel.

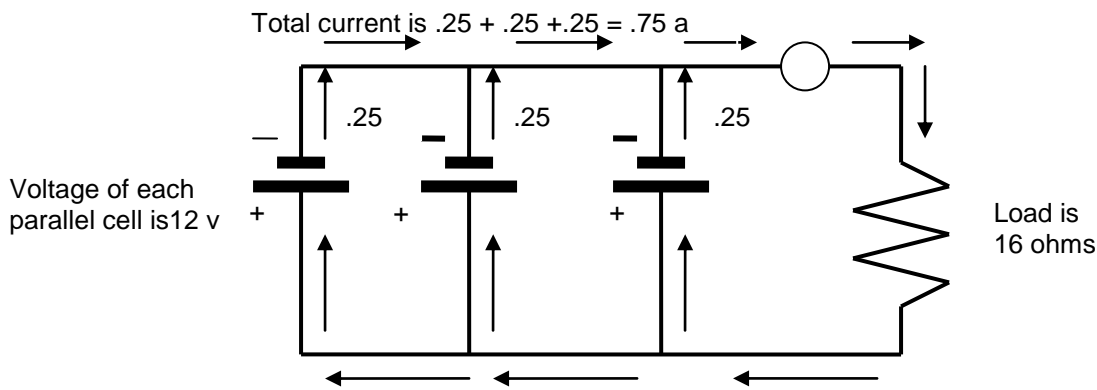

**FIGURE 4: Cells Connected in Parallel**

In the diagram:

- Each cell has a voltage of 12v, so the voltage of the circuit is 12v.
- Each cell provides .25a, so the current of the circuit is .75a.  
 $.25\text{a} + .25\text{a} + .25\text{a} = .75\text{a}$
- Resistance is equal to voltage, 12v, divided by current, .75a, which is equal to 16  $\Omega$   
 $12\text{v} \div .75\text{a} = 16 \Omega$

### Resistances in Parallel

Figure 4 showed a battery connected in parallel with just one resistance. A circuit can also have several resistances connected in parallel, each with their own branch of current. Figure 5 illustrates two resistances in parallel.

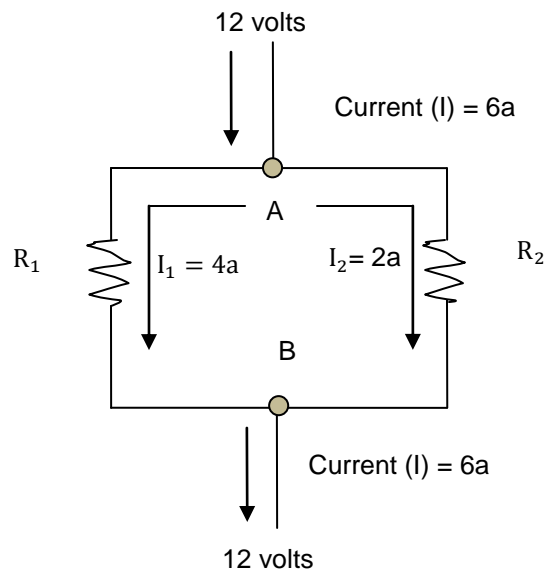

**FIGURE 5: Two Resistances in Parallel**

Notice that when the current enters at junction A, it splits and travels along separate branches to the two resistors. Only part of the current can travel along each branch. When the two currents rejoin at junction B, it goes back to its original strength. The sum of the branch currents is equal to the original current. So  $I = I_1 + I_2$ .

Now comes the complicated part. Think back to Ohm's Law:

voltage = current x resistance

$$V = IR$$

Look at Figure 5 and Ohm's Law as you read carefully through this next part.

1. Voltage (V) does not change. It is the same in the original circuit and in each of the branch circuits. Let's say  $V = 12v$ .
2.  $IR$  must always equal the value of  $V$  if the two sides of the equation are to remain equal.
3. So  $IR$  must equal  $V$  both inside each parallel branch and in the main single current wire. Recall that  $V = 12$ .
4. The original current  $I$  is larger than either branch current ( $I = I_1 + I_2$ ). Let's say  $I = 6a$ ,  $I_1 = 4a$  and  $I_2 = 2a$ . ( $6a = 4a + 2a$ )
5. Let's look at the values of  $R$  in the circuit. Before the current branches, there is no resistance but if it were located there, according to Ohm's law, its value would be:  
 $V = IR$  or  
 $R = I/V$   
 $R = 12v/6a = 2 \Omega$
6. Now let's find out what the resistance actually is in each branch.  
In the first branch:  
 $R_1 = 12v/4a = 3 \Omega$   
In the second branch:  
 $R_2 = 12v/2a = 6 \Omega$

---

Notice that each of these resistances is larger than the value the resistance would have ( $2\ \Omega$ ) if it were placed in the circuit before it branched.

7. For Ohm's law to remain true, the value of the individual resistance in each branch must be larger than the value of a single resistance located in the main circuit.

It seems strange that the two branch resistances are larger than a theoretical resistance in the main branch. However, this occurs because the relationships shown in Ohm's Law must apply everywhere in the circuit. When you find the total resistance of a parallel circuit, you are actually finding what the resistance would be if it were placed in the circuit before it branches.

Ohm's Law led to the development of the following formula for calculating the total resistance,  $R_t$ , when two resistances are connected in parallel:

$$R_t = \frac{R_1 \times R_2}{R_1 + R_2}$$

In our example where  $R_1 = 3$  and  $R_2 = 6$ , the total resistance of the circuit is:

$$R_t = \frac{R_1 \times R_2}{R_1 + R_2}$$

$$R_t = \frac{3 \times 6}{3 + 6}$$

$$= \frac{18}{9}$$

$$= 2\ \Omega$$

This is the same value we already calculated using Ohm's Law in step 5. The formula can be rearranged and written as:

$$1/R_1 + 1/R_2 = 1/R_t$$

You might see this relationship described as the following statement: *The sum of the reciprocals of resistances in parallel is equal to the reciprocal of the equivalent resistance.*

**Note:** A reciprocal is the number written as the denominator of a fraction with the numerator 1; i.e. the reciprocal of 6 is  $1/6$ .

Let's see if this formula gives us the same answer for the total resistance:

$$1/R_1 + 1/R_2 = 1/R_t$$

$$1/3 + 1/6 = 1/R_t$$

$$2/6 + 1/6 = 1/R_t \text{ Find a common denominator and add the fractions together.}$$

$$3/6 = 1/R_t$$

$$3R_t = 6 \quad \text{Cross multiply to find } R_t.$$

$$R_t = 6/3 = 2 \Omega$$

The answer for total resistance is the same. For more than two branch resistances, add as many reciprocals as there are parallel resistances. If there are four parallel resistances, the formula is:

$$1/R_1 + 1/R_2 + 1/R_3 + 1/R_4 = 1/R_t$$

**Example:** Find the total resistance  $R_t$  of a circuit with the resistances connected in parallel if the branch resistances are  $R_1 = 8$ ,  $R_2 = 1$ ,  $R_3 = 4$  and  $R_4 = 2$ .

$$1/R_1 + 1/R_2 + 1/R_3 + 1/R_4 = 1/R_t$$

$$1/8 + 1/1 + 1/4 + 1/2 = 1/R_t$$

$$1/8 + 8/8 + 2/8 + 4/8 = 1/R_t \quad \text{Use the common denominator, 8}$$

$$15/8 = 1/R_t$$

$$15R_t = 8$$

$$R_t = 8/15$$

$$= .533$$

### In Brief

The rules for resistances connected in parallel are:

- The total current is equal to the sum of the currents in the separate branches.
- The potential difference (the voltage) across all the branches of a parallel circuit must be the same.
- The reciprocal of the total resistance is equal to the sum of the reciprocals of the separate resistances in the branches.

One of the reasons you learn these calculations is to determine if a circuit is faulty. First you solve for the values of voltage, current and resistance of a given circuit. Then you measure the actual circuit. If your calculated and measured values differ by more than 10%, you probably have a faulty circuit. Different meters are used to measure the voltage, current and resistance of a circuit. These meters use both permanent magnets and electromagnets to cause a pivot to turn in order to give a reading on a scale.

There is a close relationship between electricity and magnetism. Understanding this relationship is necessary in understanding how measuring devices such as voltmeters ammeters and ohmmeters work. This relationship is also the basis for the production of alternating currents and the development of modern electronic devices.

### ***ELECTROMAGNETISM AND INDUCED CURRENT***

There is a close relationship between magnetism and electricity. Understanding this relationship is necessary in understanding how measuring devices such as voltmeters ammeters and ohmmeters work. This relationship is also the basis for the production of alternating currents and the development of modern electronic devices.

If a conducting wire is moved between the ends of a horseshoe magnet, a current starts to flow. See Figure 5. Conversely, if a magnet is moved over a wire conductor, it creates a current. If the wire or magnet stops moving, the current stops flowing.

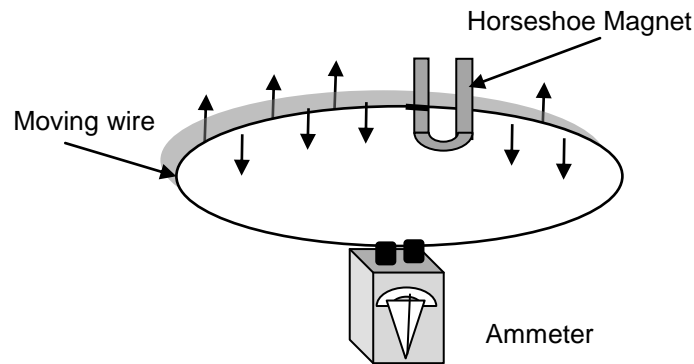

When a wire moves through a magnetic field, an electric current flows in the wire.

**FIGURE 6: Magnetically Induced Current in a Conductor**

A current created by moving a conducting wire through a magnetic field is called an ***induced current***. The process is also called electromagnetic induction.

A magnetic field can cause an induced current to flow. Conversely, a current flowing through a wire will produce a ***magnetic field*** around the wire. A magnetic field produced by a current is called ***electromagnetism***.

An electric current flowing through a conductor generates a magnetic field which consists of lines of force that flow in one direction.

- In an electrically-induced magnetic field, the direction of the lines of force in the field depends on the direction of the current.
- The strength of the magnetic field varies directly with the strength of the current.
- When the current is turned off, the magnetism disappears.

Figure 7 shows a magnetic field created by a current flowing in a conducting wire.



**FIGURE 7: Magnetic Field Created by a Current**

Moving electric charges create a magnetic field; a moving magnetic field causes charged electrons to move, creating an electric current. This close relationship between electricity and magnetism was used in the development of electric motors, generators, alternators and transformers.

In an electric motor, magnetic fields generated by electric current force a shaft to rotate. In a generator, a rotating shaft moves a magnetic field, causing a current to flow in a wire. An electric motor and a generator are basically the same device, except the cause and the effect are reversed in them.

What happens if a loop, or a coil, is made in the conductor? A strong magnetic field will be created inside the loop. If many loops are made in the conductor, a strong magnetic field can be created. This magnet is sometimes called a *solenoid*.

To increase the strength of the magnetic field, an iron bar can be inserted inside the coil. The magnet created by looping a conductor around an iron core is called an *electromagnet*. It has a north and south pole.

- *The polarity is determined by the direction the current flows.*
- To reverse the polarity, the direction of the current is reversed.
- The strength of an electromagnet depends on the number of coils in the wire and the magnitude of the current flowing in it.

### **Generators and Alternators**

Generators and alternators use the induced voltage generated by an electromagnet to recharge a battery in a vehicle. A battery provides electricity to operate the starter, the ignition system, the lights, the horn and the radio, along with any other electrical device in a car. Once all of the chemical reactions that provide the voltage of the battery have taken place, the battery can no longer provide a current unless it is recharged.

When the battery is recharged, electrical energy from an outside source provides new energy. This energy is used to return the chemical reactants to their original state. They are now ready to react again, once more providing the battery with a source of electromotive force or voltage.

The outside source of energy that drives this recharging comes from the rotation of the crankshaft. Pressure, created by combustion in the engine, causes the crankshaft to rotate which provides the movement of the wire conductor in a generator or the magnet in an alternator.

**In a generator**, a coil of wire is wrapped around an iron core. The coil rotates through a stationary magnet. The rotation is provided by a gear driven by the crankshaft of the engine.

- As the coil moves through the magnetic field, a direct current is induced.
- This current is picked up by an external circuit, where it goes to the battery, providing the energy to recharge the battery.

**In an alternator**, the wire does not rotate. Instead, a bar magnet rotates. The magnet has many coils of wire wrapped around it. The current flow is greatest when the north or south pole is closest to the coil of wire. When the north pole is closest to the coil, it induces a current that flows in a certain direction.

- As the magnet rotates, there is a point where the north and south poles are  $90^\circ$  from the wire coil and the current stops flowing.
- As the south pole comes closer to the coil, current starts to flow but in the opposite direction.
- As the magnet rotates, the current constantly flows in one direction, stops momentarily and then flows in the other direction creating an *alternating current*.

Before the current generated by an alternator can provide energy to recharge the battery, it has to be changed to a direct current.

**In an ignition system** a high voltage surge that fires the spark plugs. There are two different sizes of wire wrapped around the iron core in an ignition system coil. The heavier wire consists of about 200 windings, while the light wire consists of about 2000 windings.

- Current from the battery sets up an initial, smaller voltage in the heavy, primary wire.
- This generates a magnetic field that then induces a much larger voltage in the secondary, lighter wire.
- This high voltage creates the arc across the spark plugs, which in turn causes the ignition of the gases in the cylinder.

## **CONCLUSION**

A battery supplies the electricity to start a motor engine, fire the ignition system, and run electrical accessories such as the lights and radio. The battery uses the energy from chemical reactions to create the charges on the plates. The battery must be constantly recharged if it is to provide this energy. A generator or alternator supplies the current to recharge the battery. Both a generator and an alternator rely on the close relationship between electricity and magnetism to produce their current.

**Answer the following questions by writing the correct words in the blank spaces. The answers are on the last page.**

1. The charges on the plates in an electrical cell create an electrical force that can be made available to do \_\_\_\_\_ .
2. Two or more cells connected together are called a \_\_\_\_\_ .
3. In a battery, the electrons flow from the \_\_\_\_\_ terminal to the positive terminal.
4. When plates in a cell are connected by a wire, electrons flow from the negative plate to the positive plate because an object always tries to distribute its charges \_\_\_\_\_ over its surface.
5. The potential difference, or the voltage, created by the charged plates is measured in \_\_\_\_\_ . The symbol for volt is \_\_\_\_\_ .
6. Voltage is measured by a device called a \_\_\_\_\_ .
7. The rate of flow of electrons along the wire is called \_\_\_\_\_ . It is measured by an \_\_\_\_\_ .
8. The unit of current is the \_\_\_\_\_ . The short form or symbol for ampere is \_\_\_\_\_ .
9. An appliance in a circuit that uses electrical energy to run is called a \_\_\_\_\_ or a load.
10. The unit for measuring resistance is the \_\_\_\_\_ and the symbol for the ohm is \_\_\_\_\_

11. Label the following circuit symbols:

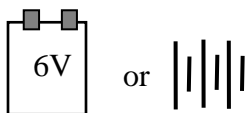

\_\_\_\_\_



\_\_\_\_\_



\_\_\_\_\_



\_\_\_\_\_



\_\_\_\_\_

- 
12. A circuit connected *in series* has three cells of 40v each. The total voltage of the circuit is \_\_\_\_\_ v.
  13. A circuit connected *in series* has three resistors of 10  $\Omega$ , 25  $\Omega$ , and 40  $\Omega$ . The value of the total resistance of the circuit is \_\_\_\_\_  $\Omega$ .
  14. In cells connected *in series*, the current is the \_\_\_\_\_ everywhere in the circuit.
  15. In cells connected *in parallel*, each individual cell must be at the same \_\_\_\_\_ as all the other cells.
  16. In cells connected *in parallel*, the total current of the circuit is equal to the \_\_\_\_\_ of the individual currents provided by each cell.
  17. Ohm's law states that the ratio of the \_\_\_\_\_ to the current is equal to the resistance of the circuit.
  18. Write the rest of the formula:  $R = \underline{\quad} / \underline{\quad}$ .
  19. If you put a battery of higher voltage in a circuit and the resistance stays the same, the current will \_\_\_\_\_.
  20. If you decrease the resistance and the voltage stays the same, the current will \_\_\_\_\_.
  21. If a circuit has a 12 volt battery, and a total resistance of 4  $\Omega$ , what is the current flowing in the circuit? Use the formula:  $I = V/R$

---

**ANSWER PAGE**

1. work
2. battery
3. negative
4. equally or evenly
5. volts, v
6. voltmeter
7. current, ammeter
8. ampere, a
9. resistance
10. ohm,  $\Omega$
11. cells or battery  
resistor  
ammeter  
open switch  
voltmeter
12. 120
13. 75
14. same
15. voltage
16. sum or the total of
17. voltage
18.  $V/I$
19. increase
20. increase
21.  $I = 12\text{v} / 4 \Omega = 3\text{a}$