

**EVALUATING  
ACADEMIC READINESS  
FOR APPRENTICESHIP TRAINING**  
Revised for  
**ACCESS TO APPRENTICESHIP**

**COMMUNICATIONS SKILLS  
INTERPRETATION OF DIAGRAMS**

**AN ACADEMIC SKILLS MANUAL  
for**

**The Small Motors Service Trades**

This trade group includes the following trades:  
Marine & Small Powered Equipment Mechanic,  
Motorcycle Mechanic and Small Motor Mechanic.

*Workplace Support Services Branch  
Ontario Ministry of Training, Colleges and Universities*

*Revised 2011*

In preparing these Academic Skills Manuals, we have used passages, diagrams and questions similar to those an apprentice might find in a text, guide or trade manual.

**This trade related material is not intended to instruct you in your trade. It is used only to demonstrate how understanding an academic skill will help you find and use the information you need.**

---

# COMMUNICATIONS SKILLS

## INTERPRETATION OF DIAGRAMS

---

*An academic skill required for the study of the  
Small Motors Service Trades*

### **INTRODUCTION**

You've probably heard this expression: "A picture is worth a thousand words." It means that something you can see would take a thousand words to explain. The purpose of graphic material (diagrams, charts, pictures) is to make information about the small motors service trades easy to see. The correct *interpretation of diagrams* is necessary in order for you to benefit from the information they contain.

The information in a diagram might illustrate a new concept, show the correct order of the steps of a procedure or give you the requirements and measurements for a tuning a carburetor. You need to be able to interpret the information on a diagram accurately so that you can complete the job successfully. Clearly, *interpretation of diagrams* is an essential skill for your technical reading toolbox.

Interpreting diagrams is essential skill to understand displays on computerized scanning equipment and sensors to locate operational information. You need to utilize diagrams to study schematics to learn how electrical, hydraulic, oil circulation and pneumatic systems operate.

Accuracy is essential in the trades. Diagrams can provide you with details about areas that you can't see or touch. When you don't have access to hidden parts, you rely on diagrams to provide the background information needed to work precisely and safely.

Other graphics such as charts and tables list details such as measurements in a way that makes it easy to find the correct component needed for a specific situation. Interpreting graphics correctly is an important skill to develop as you master the knowledge and techniques of your trade. We will look at:

- ◆ Standard symbols and diagrams.
- ◆ Symbols and diagrams as visual language.
- ◆ Diagram and text that interpret information.
- ◆ Information in text and diagrams that match.

### **PART I**

#### **STANDARD SYMBOLS AND DIAGRAMS**

#### **Graphics**

The term *graphics* refers to the various types of technical drawings and charts used in your trade. Graphics are a means of communicating information. They serve many purposes: they illustrate

concepts, show relationships, compare information and illustrate how something works, how to do something, or where something is. A chart can organize detailed information in a coherent way so you can easily find what you need. A diagram can show how something works; it can illustrate a procedure or an application; and it can show you the location of hidden features.

## Symbols

As you learn your trade, you will be introduced to many symbols. Symbols are a shortened form of language. An object, part, process, relationship or number can be converted into a symbol. Many symbols are international. When you come across a symbol in your reading or on the job, you need to learn what term the symbol stands for, and you need to know what each symbol means.

**Example:** These three international symbols demonstrate this:

×	multiplication symbol	Multiplication is indicated by the symbol <b>x</b> . The <b>x</b> symbol immediately identifies a process. It also tells you what to do.
CO <sub>2</sub>	carbon dioxide symbol	The relationship between a carbon molecule and an oxygen molecule can be stated symbolically. The symbol <b>CO<sub>2</sub></b> stands for or represents carbon dioxide. The <b>C</b> stands for a carbon molecule; the <b>O</b> stands for an oxygen molecule; the <sub>2</sub> tells you there are two oxygen molecules. Glance back over this explanation on <b>CO<sub>2</sub></b> . "A symbol is worth a thousand words".
M	number symbol for million	Many numerical amounts are represented by symbols. <b>M</b> is the first letter of the Greek word mega (great) and it is used to represent the number million.

While many symbols, such as the ones shown above, are international, some countries and some agencies have their own symbols. The International Standards Organization (ISO), the Canadian Standards Association (CSA) and the American National Standards Institute (ANSI) are different accredited groups that use their own symbols. The following extract from a table of hydraulic and pneumatic symbols tells you that *ISO* has published these symbols.

### Example:

**Table 1: Basic Hydraulic and Pneumatic Symbols**

ISO Symbols	Definitions
▼	Hydraulic Flow
△	Pneumatic flow
➤	Indication of variability

## Symbols in text

Symbols are routinely used in technical writing and in graphics.

**Example:** Most anti-friction bearings require a shaft surface finish of up to 0.30  $\mu$  m **AA** (12  $\mu$  in.). Too rough a surface finish may result in loss of interference fit, excessive shaft wear, and fretting of the bearing seat.

The purpose of the paragraph below is to provide specific information about an aspect of your trade - *shaft surface finish*. Your ability to follow the above directions depends on your ability to understand the meaning of  $\mu$  m, **AA** and  $\mu$  in. If symbols used in the text or diagrams are unclear, you need to look them up.

We have listed the meanings of these symbols below:

- $\mu$  m = symbol for micrometers. A micrometer is one millionth of a metre (0.000 001 metres)
- $\mu$  in. = symbol for micro inches. A micro-inch is one millionth of an inch (0.000 001 inch)
- AA** = refers to arithmetical average height of surface roughness

As you learn your trade, you will encounter many symbols – some will be familiar and others will be new. It is your job to learn what they mean to add to your understanding of the concepts, principles, and “language” of your trade.

### Which way is up?

Symbols help explain information.

**Example:** Objects shown at right angles can be viewed from different positions. The symbols in Figure 1 indicate the angle at which you view an object. They show whether you are viewing from left to right (**first-angle**) or from right to left (**third-angle**).

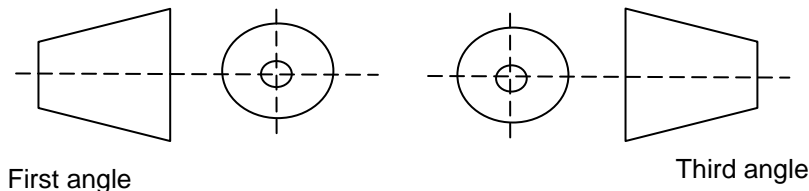

**FIGURE 1: ISO Symbols for First and Third-Angle Projections**

Symbols are shorthand for something. You need to know how to unlock the meaning presented by a symbol in a text or drawing. Each symbol transfers information to you efficiently, but you need to know precisely what it stands for. The difference between  $30^\circ$  and  $30''$  is significant.

### Purpose

*Your purpose in understanding symbols is to learn to read and speak the language of your trade. You need to interpret written material and any graphic material found in the text to understand and use all of the information presented.*

## PART II

### ***SYMBOLS AND DIAGRAMS AS VISUAL LANGUAGE***

Once you learn the meanings of trade symbols, you can recognize their meaning when you come across them in later sentences. This is the next sentence in the paragraph about shaft surface finish in the earlier example.

Babbitt and bronze sleeve bearings require a finish of up to  $0.81 \mu$  m AA ( $32 \mu$  in.).

You already know the meaning of  $\mu$  m, AA and  $\mu$  in, so you can figure out what the sentence is saying.

### Lines mean something

Lines used in technical drawings convey meaning. Lines can be *thick* or *thin*; broken, with equal spacing; broken with long or short spacing, and so on. Lines provide you with information. As with symbols, *standards apply to these lines and define their meaning* in the small motors trades. Different lines mean different things and the information they convey must be exact.

Canadian Standards define line thicknesses as *thick* or *thin*: *thick* is at least twice the thickness of *thin*. It is essential that you recognize what each line stands for in a chart or diagram. Figure 2 contains some samples to illustrate this:



Thick (solid) – outline of visible feature	
Thin (equally spaced broken) – shows hidden feature not seen	
Thick (wavy) – shortens the view of long uniform sections	

FIGURE 2: Examples of Lines in Technical Drawings

### What does this mean?

A diagram that contains lines and shapes is abstract in that it represents something real, but it doesn't look like the real thing. Look at the diagram of an automatic bleed-down circuit.

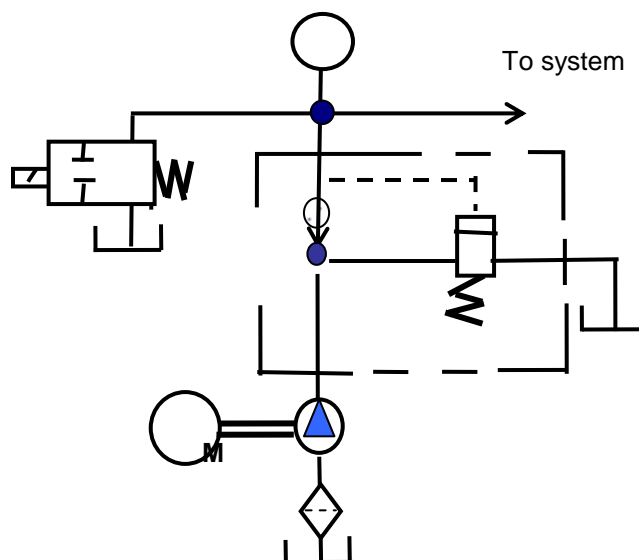

FIGURE 3: Automatic Bleed-Down Circuit

As you can see, working diagrams don't always look like what they represent. In Figure 3, the circle with **M** in the middle stands for motor. This certainly doesn't look like a motor but, when you know **M** represents a motor and you see it in a diagram, you know that the diagram includes a motor.

Each symbol you can interpret increases your ability to understand and use information presented in diagrams. Lines in drawings provide exact information about an object or a process. Figure 3 uses lines and symbols to show a series of relationships. It is a stripped down, but concise, visual language. Each part of this diagram conveys information about the placement of the following in an automatic bleed-down circuit:

- flow lines
- springs
- motor

### Road maps

Compare Figure 3 to a road map. A road map gives you an overview of a whole system: compass directions, routes, distances, names of places. From it, you can calculate distance and travelling time, determine stopping points, plan routes. A figure with each of its symbols is like a map to use as a guide to essential trade information.

## PART III

### DIAGRAMS AND TEXT THAT INTERPRET INFORMATION

#### Diagrams

Diagrams relate to something real. They show you how to do something, what something looks like, or the things that you can't see such as the flow of liquids or electrons. In some cases, the diagram looks like the real thing (such as the drawing of a tool); in other cases, it represents, but does not look like, the real thing such as this symbol for a pressure gauge.



**Pressure Gauge**

#### Figures

When you are reading, you might be directed to a graphic, which is usually labelled as a Figure with a number. The reference to the graphic may be in parentheses like this (Figure 2-10), or the text may tell what the graphic will show you.

**Example:** The spark plug, as shown in Figure 2-10, carries high voltage current produced by the ignition system. It is designed to withstand the high temperatures and shock of combustion, insulate the centre electrode against current loss, and seal against compression leakage.

---

## Read everything

Knowing the purpose of a graphic helps you interpret what is being conveyed to you. It's important to get all the information available from a graphic. The information is there to help you develop a clear understanding of the principles and concepts required by your trade.

## Labels and headings

Headings, titles and labels add to the information available in diagrams and help you interpret the information. Be sure to read all titles and headings. The labels or descriptions in a diagram identify what you are looking at; they may contain directions or point you to an important aspect of the diagram.

*Use all the information provided by labels and written descriptions within the diagram to get the complete picture.*

To interpret a diagram, start by reading the label. A label offers important information. It may

- ◆ identify the diagram,
- ◆ describe how to follow the information on the diagram,
- ◆ refer you to the text for clarification,
- ◆ highlight important points.

Diagram labels provide a focus for the information presented. Here are some samples of labels attached to diagrams. Each label gives more information than the one before it and each label relates to the graphic *and* text.

**Figure 1** An outside micrometre

**Figure 2** The parts of an outside micrometer with ratchet stop.

**Figure 3** An outside micrometer being used to measure a piston.

## Using Text and Diagram Together

Passage 1 and Figure 4 explain a process. The text explains *why* and provides details. Figure 4 lets you see *where* and *how* the action should occur. The diagram and text are important and useful on their own, but combined they provide a more complete picture.

### Passage 1 Exhaust stroke

Once the piston has completed the power stroke in a four-cycle engine, the burned gases must be removed from the cylinder before beginning a fresh charge. This removal occurs during the **exhaust stroke**. The exhaust valve opens and the piston rises, pushing the exhaust gases from the cylinder.

### Cooling the valve

The heat that the exhaust valve absorbs during this stroke needs to be controlled or it can suffer rapid deterioration. Some of this cooling occurs through conduction through the valve stem to the guide. The hottest part of the valve (the valve head), transfers heat through the valve seat to the cylinder block.

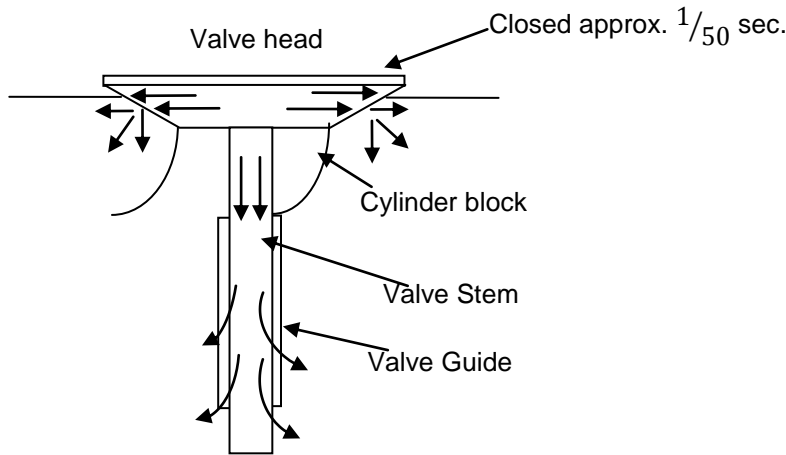

**FIGURE 4: Cooling the Valve**

Heat is conducted from the valve through the seat to the cylinder block. Some heat conducts down the stem and to the valve guide. This cooling must occur very quickly ( $1/50$  sec, at 3600 rpm).

The diagram above has a clear purpose. It gives you a good idea of how heat is controlled in a valve. It is labelled so that you can identify the parts. It is simplified: you get enough information to see an operation, but not so much that it distracts you from key details. Note that information about the direction of movement of heat is shown by symbols – arrows.

The diagram aids your understanding of one aspect of the exhaust stroke. You can "see" the following:

- valve stem,
- valve guide,
- cylinder block,
- heat transferring from the valve head to the cylinder block,
- heat flowing down the valve stem,
- heat leaving through the valve guide, and
- the rate at which cooling must occur ( $1/50$  sec).

By reading the description at the bottom of the diagram and by looking carefully at the diagram, you can probably figure out much of what is happening.

The text provides further explanations and directions not found in the diagram. The text provides explanations and directions not found in the diagram. The diagram and the text differ; yet, **they work together** to describe a process and to provide a mental and visual picture of what happens.

When you have read and understood both the graphic and the text, you should be able to:

1. Explain the *exhaust stroke* and the function of the piston and exhaust valve during this stroke.
2. Explain when heat needs to be transferred and how quickly.
3. List two ways heat is transferred from the exhaust valve.

### How not to . . .

Technical drawings often show you how to do something. The text describes the actions to be done and explains the reasons for doing them, while the drawings show how to perform those actions. Examining both text and drawings helps you accurately follow directions and avoid problems.

In the next passage, the text describes the function and uses of castle nuts and how to install a cotter pin correctly. The diagrams illustrate both correct and incorrect ways.

#### Passage 2 The Castle Nut

Castle nuts are used on bolts that have a drilled hole through the threaded end (see Figure 5). A cotter pin is used to prevent the nut from turning and should always be installed properly as shown in Figures 5A and 5B. Castle nuts are used on bolts, or shafts when a component turns or pivots on it. They are also used when *axial clearance* is required, for example, with axle shafts having tapered roller or ball.

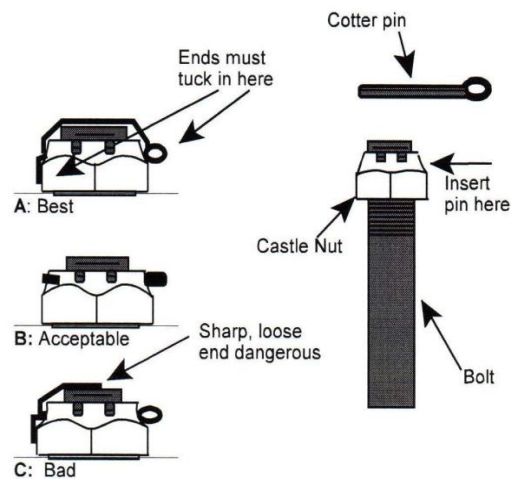

Figures 5A and 5B are acceptable installation methods of the cotter pin, while 5C is incorrect. The pin is placed through the castle nut and bolt hole to prevent the nut from coming off the bolt. Method 5A is the most difficult to produce, but it will eliminate a sharp end.

### Read it all

When we look at diagrams, charts, or tables, we need to refer back to *the guidance of the text*. The text tells us when to refer to the diagram and directs us to specific aspects of a drawing. The text may repeat or emphasize important points.

The text in Passage 2 directs you to Figures 5A, 5B and 5C. Make sure you find the corresponding spot on the diagram. Next, the text directs your attention to a point on the diagram:

Figures 5A and 5B are acceptable installation methods of the cotter pin, while C is incorrect. The pin is placed through the castle nut and bolt hole...

Make sure you find the corresponding spot on the diagram. It is illustrated so that you can see it and understand it. You need to be sure that you are seeing exactly what you are supposed to see.

The rest of the paragraph gives you a reason why method A is the best:

.....but it will eliminate a sharp end.

Figure 5C shows you incorrect installation. After comparing correct and incorrect methods, you should be able to apply these directions. Further, the visual information should help you remember how to do this and why it is important to do it right.

### **Test yourself**

Assess how well you are interpreting diagrams. If we removed the references to the figures in the text above (e.g. Figure 5 A, B and C), could you:

1. Match the text and diagrams correctly?
2. Demonstrate the correct method of installation and which is incorrect?
3. Explain why? If it is not clear, read and then reread. Match diagram to text and text to diagram as you go. Find spots on the diagram the way you would pick out points on a map.
4. Compare the diagrams and refer to the text?
5. Piece together possible consequences of incorrect installation?

If you can answer yes to the questions above, you have correctly interpreted the information.

## ***PART IV INFORMATION IN TEXT AND DIAGRAMS THAT MATCH***

### **Stop and read the diagram**

A diagram relates to something real, whether it is a piston or the symbol for “combustible” on a product label. You need to be able to convert the information into language and later into actions. The first step is to understand what is being depicted by the diagram. Describe to yourself, in your own words, what the diagram represents. If you don’t recognize certain symbols, look them up.

Read Passage 3 below and identify places or points on the diagram that correspond to the main text. The text explains what is happening; the diagram converts this information into something visual.

#### **Passage 3 The Heat Pump**

A system used in refrigeration, air conditioning, and house heating is shown in its essentials in Figure 6. The freezer compartment of an electric refrigerator (for household use) is an example of an evaporator. The chambers are double-walled and contain a liquid that evaporates very readily. This works much like the cooling that takes place when liquids such as gasoline, cleaning solvents or water evaporate from your hands. The faster the liquid evaporates, the cooler the effect; in other words, heat is removed at a quicker rate.

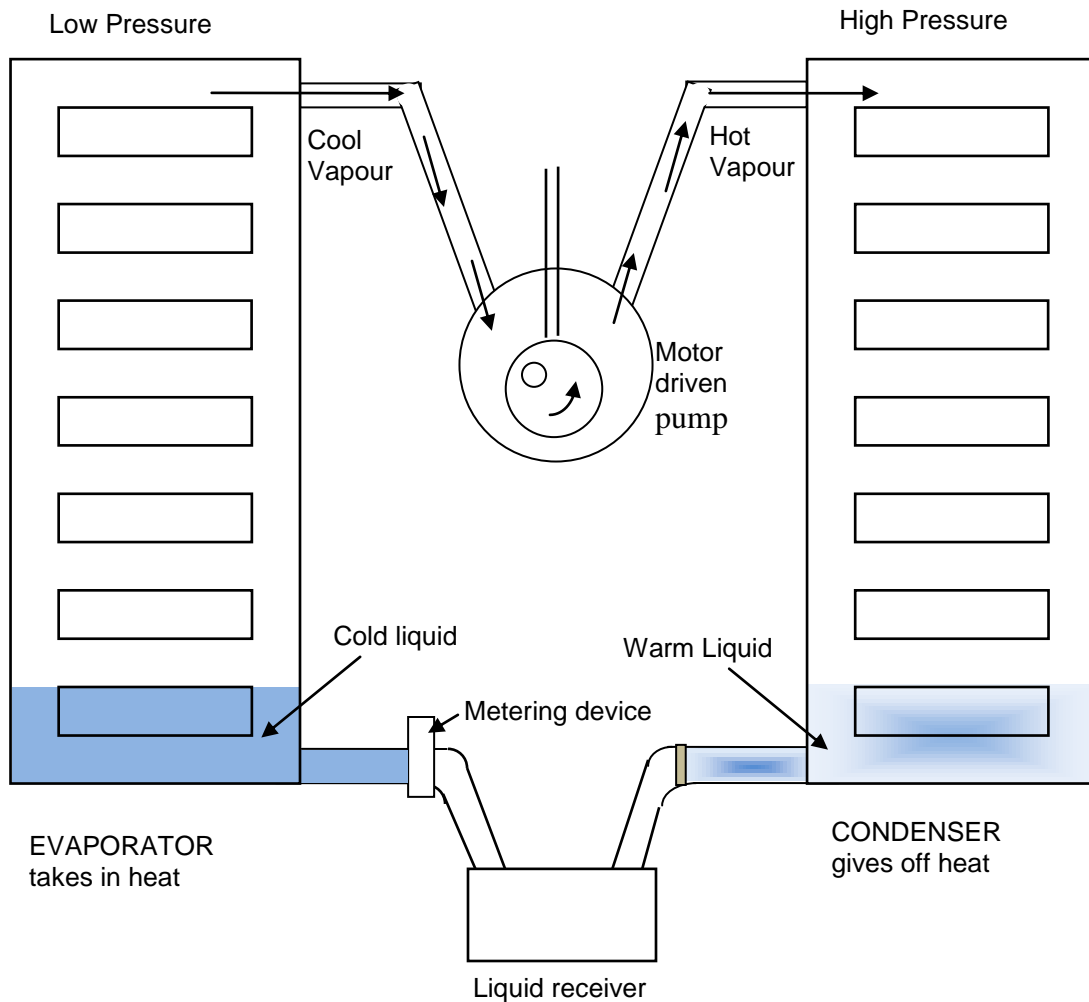

**FIGURE 6:** A Heat Pump

When the insides of a refrigerator warm a little, a thermostat activates an electric motor that runs a pump. The pump moves vapour away from the liquid in the evaporator. As a result, more liquid is allowed to evaporate. As the liquid evaporates, it draws heat from the metal evaporator and from everything nearby. The vapour that goes through the pump is warmed by compression. The now hot vapour, under pressure, is cooled in the condenser to the point where it changes to liquid. It now gives off the heat that it absorbed in the evaporator when it became vapour. The air in the room cools the condenser; that is, it draws heat from the condenser.

**Answer the questions using information from both the text and diagram. Answers are at the end of this skills manual.**

1. The vapour will be at its warmest:
  - a) just **before** going through the pump.
  - b) just **after** going through the pump.
  - c) There is no difference.

- 
2. Which sequence of information is correct, **A** or **B**?
    - A.** a) electric motor starts  
b) vapour is pumped away from liquid in evaporator  
c) more liquid evaporates  
d) heat is withdrawn from evaporator
    - B.** a) electric motor starts  
b) liquid goes through pump  
c) and is warmed by compression  
d) under pressure it is cooled in condenser
  3. To make the device work as a house heater (that is to warm air inside the house), you would:
    - a) put evaporator in the house so it can warm air inside the house.
    - b) put condenser in the house so it can warm air inside the house.

## **CONCLUSION**

The text that accompanies a diagram is directly related to it. They are partners. Usually the main text explains in words the information you see in a diagram. It also directs you at the appropriate time to study the diagram. It tells you what you should look for in the diagram.

When you use the information from both text and graphics, you develop a clearer understanding of a principle, a procedure or a type of equipment. Use text and diagrams together to enrich your learning. They can clearly show you a complex idea in a small space.

When the text describes steps in a process and the diagram illustrates it, you can follow the information flow. Your eyes can move in all directions. You can *see* the information from different points in the process. You can interpret what is happening at different stages.

Technical diagrams and symbols transfer information. Provided you read carefully and interpret correctly, graphics can do any of the following in little space and at a glance:

- ◆ show relationships,
- ◆ make abstract ideas easier to understand,
- ◆ show you something invisible or hidden, and
- ◆ focus on and emphasize important aspects on information.

## **Summary**

1. **Symbols are a form of shorthand.** Understand what these symbols represent to understand the language of your trade. Note any differences between countries.
2. **Lines convey information.** Lines and symbols can show relationships, objects and processes.
3. **Diagrams (graphics) use a visual approach** to make technical information meaningful.
4. **Diagrams are labeled clearly** to identify parts and their relationships.

5. **The text and diagram are directly related to each other and work as partners.** Always use them together.
6. **Always read the description that accompanies each diagram.** They tell you what you are looking at and what to look for.
7. **Diagrams and symbols relate to something you need to know.** Interpret and connect them to achieve understanding.

---

## Answer Page

### **PART IV, Heat Pump and Diagram.**

1. The vapour will be at its warmest:  
b) just **after** going through the pump.

The text states, "The vapour which goes through the pump is warmed by compression. The now hot vapour, under pressure, gets cooled in the condenser to the point. . ." The vapour is described as being **hot** as it is warmed by compression - not before compression.

The diagram makes this clearer: the vapour (top left) is **cool**. After going through the pump, it is **hot**.

2. Which information is correct, **A** or **B**?

**A**

- a) electric motor starts
- b) vapour is pumped away from liquid in evaporator
- c) more liquid evaporates
- d) heat is withdrawn from evaporator is the correct information.

The text provides this in the same sequence. The diagram shows the changing states of liquid to vapour and shows with arrows the flow of vapour. No liquid goes through the pump.

3. To make the device work as a house heater (that is to warm air inside the house), you would

- b) put condenser in the house so it can warm air inside the house.

The text states, "The now hot vapour, under pressure, gets cooled in the condenser to the point where it changes again to liquid. It now **gives off the heat that it absorbed in the evaporator. . .** The air of the room cools the condenser; **that is, it draws heat from the condenser.**"

The diagram shows this very simply. The word condenser clearly labels the drawing of a condenser and clearly states below the diagram that it "gives off heat."